



Instruction Manual

VT20



HOW-TO-VIDEOS AVAILABLE

CLICK HERE FOR ACCESS

Table of Contents

Introduction / Warnings	01 / 02
Battery Installation	03
Charging the Battery	04
Battery Maintenance	05
Master Code Programming	06
Product Registration	07
Hot Keys	08 / 09
Tamper Detection	08
Stealth Mode	08
Travel Mode	08
View Battery Status	08
Toggle Interior Light ON/OFF	09
Vaultek™ App	09 / 10
Securing Your Safe	11
Customer Support / Warranty	12
FAQ	13 / 14

Box Contents

VT20 Vaultek™ Safe

18650 Rechargeable Lithium-ion Battery

AC Power Adapter and Micro-USB Charging Cable

High Strength Steel Security Cable

Hardware Mounting Kit

Owner's Manual

Backup Keys (2)

Phillips Head Screwdriver

Vaultek™ App!

The Vaultek™ app is available for Android and iOS devices. The app allows you to perform tasks such as remotely unlocking safe, checking battery level, toggling sound ON/OFF, adjusting the interior light, plus much more. Learn more about the Vaultek™ app on page 10.

How-To-Videos

Listed below are some of the various how-to-videos on VAULTEKSAFE.COM.

Installing Your Battery

How to Register Your Safe

Change Your Master Pin Code

Overview of the Bluetooth App

How to Anchor Your Safe

Hot Keys Available

More videos online.

HOW-TO-VIDEOS AVAILABLE [CLICK HERE FOR ACCESS](#)

Introduction

The Vaultek™ VT20 is a PIN access / Bluetooth access safe. Its solid structure and penetration resistant design makes it ideal for storing valuables such as firearms, jewelry, cash and other personal items. Powered by a rechargeable lithium-ion battery, the VT20 combines security with complete access control.

Secure Access: How to open your Vaultek™ Safe.

Keypad: The numeric keypad responds quickly for rapid access and has a built-in proximity sensor that lights up when your hand brushes against the safe. See page 06 for more information.

Vaultek App: Open the safe with the Bluetooth app. See pages 09 and 10 for more information.

Key: Two keys are provided for manual access to the safe in the event the battery dies.

Secure Defense: How your Vaultek™ Safes keeps people out.

Anti-Impact Latches: Built to withstand forceful impacts and heavy slams.

Unibody Construction: Our single unibody design is extremely strong without welds or weak points.

No External Access Points: A combination of interior mounted hinges and anti-pry reinforcement bars help prevent unwanted tools from attempting to break the safe open.

Security Sleep Mode: Activates when six (6) consecutive incorrect keypad entries are made and does not accept any entries for two minutes. If a button is pressed during this mode, all of the numbers will flash RED and the alarm beeps. A backup key or programmed fingerprint may be used to open the safe.

Warnings

To prevent damage to your Vaultek™ unit or injury to yourself or to others, read the following safety precautions before using this unit.

DO NOT PLACE OR STORE THE BACKUP KEYS INSIDE THE SAFE AT ANY TIME. IF THE BATTERY FAILS, YOU WILL BE UNABLE TO OPEN THE SAFE.

DO NOT get the sensor area wet.

DO NOT expose to extreme heat or cold. Battery power may be affected.

ALWAYS check to make sure door has latched when closing: **lid requires a firm press.**

DO NOT store **loaded** guns in this unit.

DISCLAIMERS

NEITHER SELLER NOR MANUFACTURER SHALL BE LIABLE FOR ANY INJURY, LOSS OR DAMAGE, DIRECT OR CONSEQUENTIAL, ARISING OUT OF THE USE OF, OR THE INABILITY TO USE, THE VAULTEK™ SAFE.

THE USER SHALL DETERMINE THE SUITABILITY OF THE VAULTEK™ SAFE BEFORE THE INTENDED USE AND USER ASSUMES ALL RISK AND LIABILITY WHATSOEVER IN CONNECTION THEREWITH.

HOW-TO-VIDEOS AVAILABLE [CLICK HERE FOR ACCESS](#)

Battery Installation

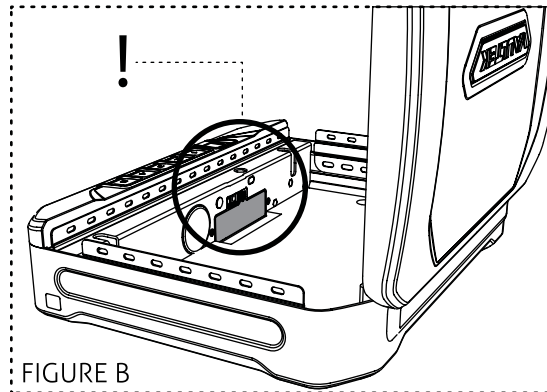
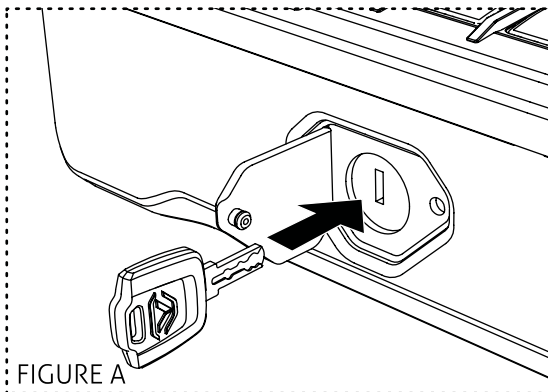

- 1 To get started, insert one of your backup keys into the keyhole (see Figure A). Push key in and rotate the key 90 degrees clockwise to open the safe.
- 2 Remove crate foam insert. Locate the battery compartment door on the inside of the safe directly behind the '1' key on the keypad (see Figure B).
- 3 Using the Phillips screwdriver provided open the battery cover by removing the **single screw** in the top center of the battery cover.
- 4 Insert the 18650 rechargeable lithium-ion battery (included in box) into the battery compartment. Note that your Vaultek™ safe automatically detects the polarity of the battery and can be installed in either direction.
- 5 When the battery is inserted you will hear a short welcome tone and the keypad will light up.
- 6 Once you hear the tone and see the lights, replace the battery cover and screw. You are now ready to program your safe. See page 06.

Charging the Battery

Your Vaultek™ safe is powered by a rechargeable lithium-ion battery and comes with a charging kit which includes an AC power adapter (suitable for 120 volt power outlets) and a micro-USB cable.

Under normal usage, the battery can last at least 4 months. To recharge the safe, plug the micro-USB cable into the micro-USB receiving jack located on the lower right side of the safe (Figure C) and connect to a standard USB port or wall outlet using the AC power adapter. Approximate recharge time is 2.5 hours. During recharging, the white LEDs above the micro-USB jack (Figure C) indicate the battery capacity as below:

- 4 lights glow: Fully recharged
- 3 lights glow, 1 light blinks: 80%~100%
- 2 lights glow, 1 light blinks: 60%~80%
- 1 light glows, 1 light blinks: 40%~60%
- 1 light blinks, less than 20%

The charging kit can also function as an external power supply, which means you can open your safe even when the battery is depleted.

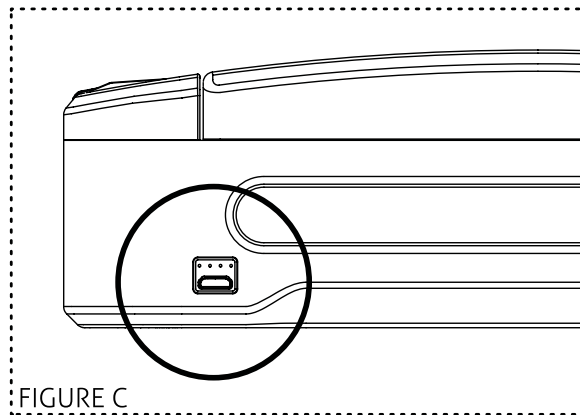

FIGURE C

IMPORTANT

After installing the battery, use the charging kit provided to charge the unit 100%.

HOW-TO-VIDEOS AVAILABLE [CLICK HERE FOR ACCESS](#)

Battery Maintenance

Testing the Battery Power

To check the battery level, press and hold the '5' button on the keypad (3 seconds). The button from '1' to '4' will glow GREEN or RED to indicate the battery level:

Remaining Battery Capacity Level

If 4 digits glow green: 80%-100%

If 3 digits glow green: 60%-80%

If 2 digits glow green: 40%-60%

If 1 digit glows green: 20%-40%

If 1 digit glows red: 2%-20%

If 1 blinks red: less than 2%

Low Battery

If '1' button on the keypad blinks 5 times and you hear a beep when opening the safe, your battery level is critically low and your safe needs to be charged immediately.

IMPORTANT

Replace the battery with an 18650 rechargeable lithium-ion battery when one or more of the following occurs: A) all four of the white lights above the micro-USB jack are blinking or B) it takes more than 4 hours to recharge the battery. (Refer to the "Battery Installation" section for instructions).

The adapter used to charge the battery should output 5V/1000mA or above using micro-USB.

Master Code Programming

First time users should change the default code as soon as possible to prevent unauthorized access to your safe. You will also use this master code in the Vaultek™ app on your smartphone, so it should be kept confidential.

TIP; Code Requirements

- Your code can be a minimum of 4 and a maximum of 8 keypad entries.
- Two keys cannot be pressed simultaneously.
- Programming a new code will overwrite your previous code.

- 1 Enter default code 1-2-3-4-5 on the keypad to open the safe.
- 2 With the safe open, press and hold the "PROGRAM" button (3 seconds) (Figure D) until all keys (1-5) light up RED and let go.
- 3 Enter your NEW master code.
- 4 Press and hold the "PROGRAM" button again (3 seconds) until all keys (1-5) light up RED and let go.
- 5 Enter your NEW master code a second time.
- 6 Press and hold the "PROGRAM" button a third time (3 seconds) until the safe beeps and let go. This tone confirms that the password has been reset.

If you make a mistake and the new code will not work, simply start over with step 2.

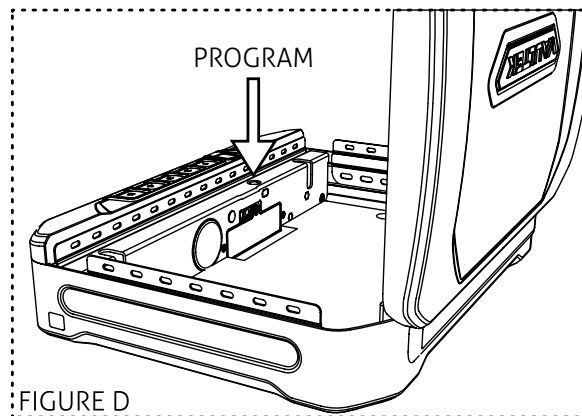

FIGURE D

HOW-TO-VIDEOS AVAILABLE [CLICK HERE FOR ACCESS](#)

Product Registration

Vaultek™ strongly encourages you to register your safe as soon as you receive it. Registration provides many benefits including technical support and ordering replacement keys should you misplace them. Your Vaultek™ safe has a unique product number on the inside of the battery door and a 4-digit ID number engraved on the keys. You will need these numbers to register your safe.

- 1 Locate your product number. It is printed on the first page of your user manual and on the back of the battery door (Figure E/F).
- 2 Find your 4-digit ID number engraved on the keys (Figure G).
- 3 Please visit the Vaultek™ website at VAULTEKSAFE.COM and click Support.
- 4 Enter the required information in the form and click submit.

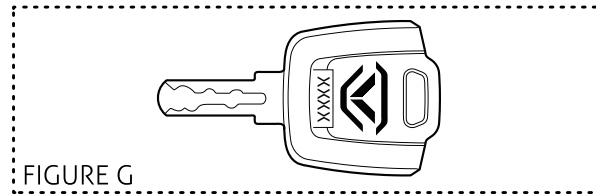
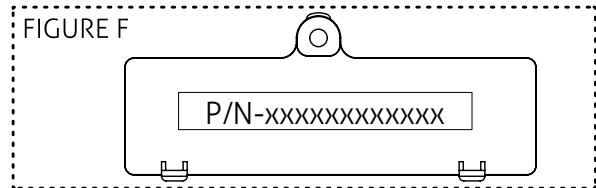
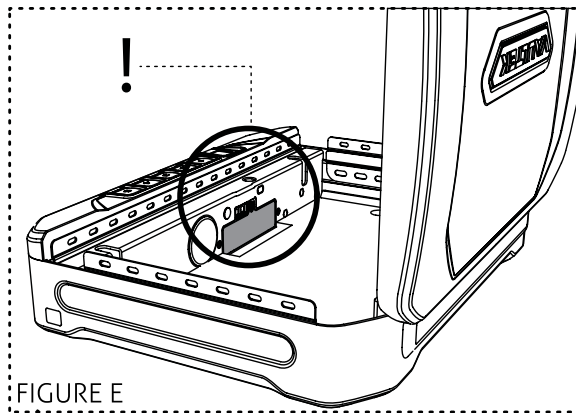

HOW-TO-VIDEOS AVAILABLE [CLICK HERE FOR ACCESS](#)



Tamper Detection

Press and hold '2' and '4'

To check for tampering press and hold the '2' and '4' keys at the same time for 3 seconds. The '3' key will glow RED to indicate tampering or GREEN to indicate no tampering. You can reset the tamper detection by entering the master code on the keypad.



Stealth Mode

Press and hold '1' and '3'

You can toggle the sound ON/OFF by pressing and holding buttons '1' and '3' in combination for 3 seconds. If button '2' glows GREEN, the sound is ON; if button '2' glows RED, the sound is OFF.



Travel Mode

Press and hold '1', '3' and '5'

Save battery life by disabling the proximity sensor, keypad, and Bluetooth features. To toggle travel mode ON/OFF press and hold buttons '1', '3', and '5' at the same time until safe beeps.



View Battery Status

Press and hold '5'

To check the battery level, press and hold the '5' button on the keypad (3 seconds). The button from '1' to '4' will glow GREEN or RED to indicate the battery level.

If 4 digits glow green: 80%-100%

If 3 digits glow green: 60%-80%

If 2 digits glow green: 40%-60%

If 1 digit glows green: 20%-40%

If 1 digit glows red: 2%-20%

If 1 blinks red: less than 2%



Toggle Interior Light ON/OFF

Press and hold '1'

To toggle the interior light ON/OFF press and hold '1' for 3 seconds. With the light toggled to ON you can press the "LIGHT" button inside the safe to illuminate the light and can also adjust the interior light in the app. If the light is toggled OFF these feature will be disabled.

Vaultek™ App

The Vaultek™ app lets you get the most out of your Vaultek™ safe. Using the app gives you access and control over features that are not possible using the keypad interface alone.

Get the App

Download and install the Vaultek™ app from the Google Play Store, or Apple Store.

IMPORTANT:

Create a pattern lock on the Vaultek™ app as soon as possible to prevent unauthorized access to your safe.

You must be within Bluetooth range and connected to your Vaultek™ safe before any of the features will function.

HOW-TO-VIDEOS AVAILABLE [CLICK HERE FOR ACCESS](#)

Pair with Vaultek™ Safe

- 1 From your phone/tablet, make sure Bluetooth is ON and discoverable by other devices.
- 2 Open the app and search for your Vaultek safe from the device list.
- 3 You will enter your master code you previously programmed for the safe to finalize set up.
- 4 Your safe is now paired and ready to use with the app.

Pattern Lock

- 1 From your device, open the Vaultek™ app and click the drop down menu located on the top left.
- 2 Select the "Pattern Lock" and toggle ON.
- 3 Create your personal lock code.

App Features

Remotely Unlock Safe

While in Bluetooth range you can remotely open the safe with the Vaultek™ app.

Check Battery Level

A battery meter shows the remaining battery power.

Toggle Sound ON/OFF

You can toggle the system sounds ON/OFF.

Adjust Interior Light

You can vary the brightness on the internal light of the safe from 0-100%.

History Log

Track the time and date changes were made to the safe. Those changes may include when someone unlocked the safe and how they unlocked the safe, any changes to the settings of the safe including brightness, sound, master code changes, any deleted users, and much more.

Securing Your Safe

Your Vaultek™ safe can be secured a few different ways. Included in the box is a security cable to attach your safe to larger stationary objects. There are also mounting screws included to insert into the pre-drilled holes on the bottom of the safe to mount to a flat surface.

Using the Security Cable

- 1 Loop the security cable around a secured object.
- 2 Run the end of the cable through the eye of the other end and pull tight around the object.
- 3 Place the stud on the loose end of the security cable through one of the mounting holes on the back side of the Vaultek™ safe as shown in (Figure H).
- 4 Screw the provided nut onto the stud and tighten.

Using the Mounting Screws

TIP: Make sure you have enough clearance for the lid to open properly before mounting the safe.

- 1 Position the safe on a flat surface where you want to mount it.
- 2 Use a pencil to mark the holes for drilling.
- 3 Drill pilot holes.
- 4 Position safe in place and tighten screws into the pilot holes.

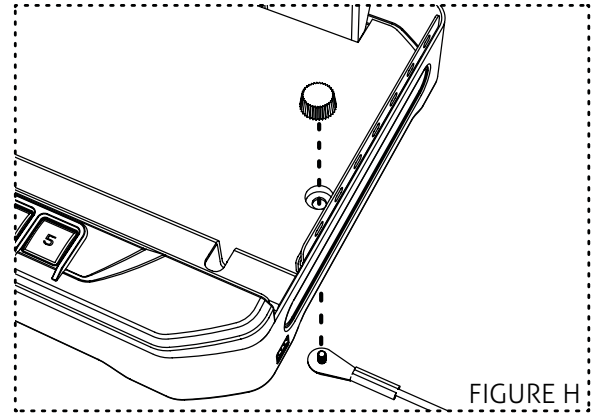

IMPORTANT:

Mounting the safe vertically so that the door flips upward will result in incomplete opening of the safe door due to weight of the safe door. The door will open if the safe is mounted vertically so that door opens down or to the side.

Customer Support and Warranty

Customer Support

If you have a problem with your Vaultek™ safe that is not answered in the FAQ section of this manual, we encourage you to email us: SUPPORT@VAULTEKSAFE.COM.

Warranty

VAULTEK™ IS COMMITTED TO PROVIDING PRODUCTS OF HIGH QUALITY AND VALUE AND MAKES EVERY EFFORT TO ENSURE ITS PRODUCTS ARE FREE OF DEFECTS.

Vaultek™ guarantees your safe will be free of defects in materials or workmanship for a period of one year from the date of original purchase from an authorized dealer. This warranty does not cover abuse, misuse, use in any manner for which is not designed, neglected, modification, damage, inadvertently caused by the user, accidents, and/or tampering.

If your safe is determined to be defective, we will at our discretion, have it repaired at our expense, or will send you a new one at no cost to you. You will be required to return your existing unit as well as all included parts to Vaultek™ prior to replacement along with your proof of purchase.

If it is determined your safe needs to be returned, a Vaultek™ agent will provide a Return Authorization Number. Please have the following information available when you contact us:

- Purchaser's name, mailing address, email address, and a phone number.
- Copy of receipt
- Authorized Dealer Name
- Detailed description of problem

NEITHER SELLER NOR MANUFACTURER SHALL BE LIABLE FOR ANY INJURY, LOSS OR DAMAGE, DIRECT OR CONSEQUENTIAL, ARISING OUT OF THE USER OF, OR THE INABILITY TO USE THE VAULTEK™ SAFE.

FAQ

Q: What happens to the master code that is stored in my Vaultek™ safe when the battery dies?

A: The safe retains the master code in the event of battery failure. Once the power is restored by inserting the AC adapter cable, the unit will function as it did before the power loss.

Q: Is my Vaultek™ safe fire proof or water proof?

A: No, the safe is not fire proof nor water proof. This safe has been specifically designed for portable secure access control and convenience.

Q: What do I do when my safe is unresponsive to keypad?

A: Your battery is likely dead. Plug in the AC adapter and your safe should recharge the battery and function normally. If your battery has failed, you may need to use the backup key provided with the unit to open and replace the battery.

Q: What type of battery does my Vaultek™ safe use?

A: The safe uses a Model 18650 rechargeable lithium-ion battery. It is commonly available 3.7V, 2800mAh battery. If replacing, make sure the capacity of the new battery is over 2000mAh.

STOP! Do not return to retailer. If you have any questions about your Vaultek™ safe or need help configuring the system, please contact us at VAULTEKSAFE.COM.

HOW-TO-VIDEOS AVAILABLE [CLICK HERE FOR ACCESS](#)

Q: Can I travel with my Vaultek™ safe through US Customers or TSA Security at the airport?

A: Yes, there are no restrictions on carrying this type of item. Please be aware that you may be asked to open your safe rather than passing it through x-ray, and that we recommend that an enrolled user be present during the transport of this item in case such a request is made by a government authority.

Q: What is the safe made of?

A; The main housing structures are made of high tensile strength 16-gauge carbon steel with a durable powder coating for corrosion protection.

Don't see your question answered.
Send us your question at [VAULTEKSAFE.COM/SUPPORT](https://www.vaulteksafe.com/support).

HOW-TO-VIDEOS AVAILABLE [CLICK HERE FOR ACCESS](#)



VAULTEK®

37 North Orange Ave. Suite 800B Orlando, FL 32801

VAULTEKSAFE.COM