



Instruction Manual

VT20

Thank You For Your Recent Purchase

At Vaultek® we stand behind our product and you our customer. On behalf of the entire team thank you for your purchase. We believe personal defense should be handled seriously and we're excited for you to experience the ultimate performance in smart-security.

STAY SAFE. VAULTEK® SAFE.

Table of Contents

Introduction / Warnings	01 / 02
Battery Installation	03
Charging the Battery	04
Battery Maintenance	05
Master Code Programming	06
Product Registration	07
Hot Keys	08 / 09
Tamper Detection	08
Stealth Mode	08
Travel Mode	08
View Battery Status	08
Toggle Interior Light	09
Toggle Bluetooth®	09
Vaultek® App Features / App Pairing	09 / 10
Securing Your Safe	11
Customer Support / Warranty	12
FAQ / Troubleshooting	13 / 16

Box Contents

Vaultek® Safe
18650 Rechargeable Lithium-ion Battery
AC Power Adapter and Micro-USB Charging Cable
High Strength Steel Security Cable
Hardware Mounting Kit
Owner's Manual / Quick Start Guide
Backup Keys (2)

Vaultek® App!

The Vaultek® app is available for Android and iOS devices. The app allows you to remotely unlock safe, check battery level, toggle sound ON/OFF, adjust the interior light, plus much more. See pages 09 and 10 for more information.

Tutorial Videos

Listed below are some of the various tutorials available at vaulteksafe.com.

Installing Your Battery
How to Register Your Safe
Change Your Master Pin Code

Overview of the Bluetooth® App
Hot Keys Available
More videos online.

GET STARTED

**VaultekSafe.com/
20Series-Support**

ONLINE TUTORIALS
Quick setup help.

Introduction

The Vaultek® is a PIN access / Bluetooth® access safe. Its solid structure and penetration resistant design makes it ideal for storing valuables such as firearms, jewelry, cash and other personal items. Powered by a rechargeable lithium-ion battery, the safe combines high security with complete access control.

Secure Access: How to open your Vaultek® Safe.

Keypad: The numeric keypad responds quickly for rapid access and has a built-in proximity sensor that lights up when your hand brushes against the safe. See page 06 for more information.

Vaultek® App: Open the safe with the Bluetooth® app. See pages 09 and 10 for more information.

Key: Two keys are provided for manual access to the safe in the event the battery dies.

Secure Defense: How your Vaultek® Safe keeps people out.

Anti-Impact Latches: Built to withstand forceful impacts and heavy slams.

Unibody Construction: Our unibody design is extremely strong without welds or weak points.

No External Access Points: A combination of interior mounted hinges and extended anti-pry reinforcement bars help prevent unwanted tools from attempting to break the safe open.

Mounting Feature: Secure your safe to a stationary object via the included high strength steel security cable or via the two pre-drilled mounting holes using the included mounting hardware.

Security Sleep Mode: Activates when six (6) consecutive incorrect keypad entries are entered and does not accept any entries for four minutes. If any additional attempts are made the alarm will beep. The security sleep mode can be cleared upon unlock of the safe by any authorized access method including the backup keys.

Warnings

To prevent damage to your Vaultek® unit or injury to yourself or to others, read the following safety precautions before using this unit.

DO NOT PLACE OR STORE THE BACKUP KEYS INSIDE THE SAFE AT ANY TIME. IF THE BATTERY FAILS, YOU WILL BE UNABLE TO OPEN THE SAFE.

DO NOT expose to extreme heat or cold. Battery power may be affected.

DO NOT store loaded guns in this unit. Firearms are serious in nature and must be handled with respect. Store responsibly.

ALWAYS check to make sure door has latched when closing; lid requires a firm press and locks automatically.

DISCLAIMERS:

NEITHER SELLER NOR MANUFACTURER SHALL BE LIABLE FOR UNAUTHORIZED ACCESS, ANY INJURY, LOSS OR DAMAGE TO PERSONAL PROPERTY DIRECT OR CONSEQUENTIAL, ARISING OUT OF THE USE OF, OR THE INABILITY TO USE THE VAULTEK® SAFE.

THE USER SHALL DETERMINE THE SUITABILITY OF THE VAULTEK® SAFE BEFORE THE INTENDED USE AND USER ASSUMES ALL RISK AND LIABILITY WHATSOEVER IN CONNECTION THEREWITH. VAULTEK® SAFES ARE NOT INTENDED TO PROTECT AGAINST ENVIRONMENTAL HAZARDS INCLUDING FIRE AND WATER.

Be sure and follow all local and state firearm laws.

DO NOT operate a firearm without proper training and experience.

The Bluetooth® word mark and logos are registered trademarks owned by the Bluetooth SIG, Inc. and any use of such marks by Vaultek Safe, Inc. is under license.

Battery Operation

Your safe uses a 3.7V 18650 rechargeable lithium-ion with a flat top. A minimum 2000 mAh capacity is required, however 2200 mAh or higher can be used to increase operation time. A high capacity battery upgrade is available as an accessory through our website.

Battery Installation

- 1 To get started, insert one of your backup keys into the keyhole at the front of the safe (see Figure A). Push key in and rotate the key 90 degrees clockwise to open the safe.
- 2 Remove the interior padding. Locate the battery compartment door on the inside of the safe directly behind the '1' key on the keypad (see Figure B).
- 3 Remove the battery cover by pressing down on the tab near the top of the cover.
- 4 Insert the battery (included in accessory box) into the battery compartment. Note that your Vaultek® safe automatically detects the polarity of the battery and can be installed in either direction.

TIP! For easy removal make sure to place the pull string over the battery before closing the door.

- 5 When the battery is inserted you will hear a short welcome tone and the keypad will light up. Once you hear the tone and see the keypad light up, replace the battery cover. You are now ready to program your safe.

IMPORTANT Your Vaultek® safe will automatically lock when you fully close the lid.

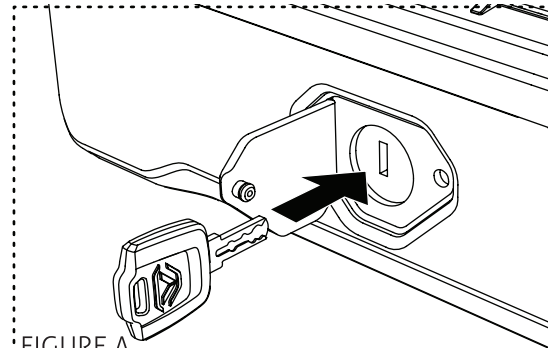

FIGURE A

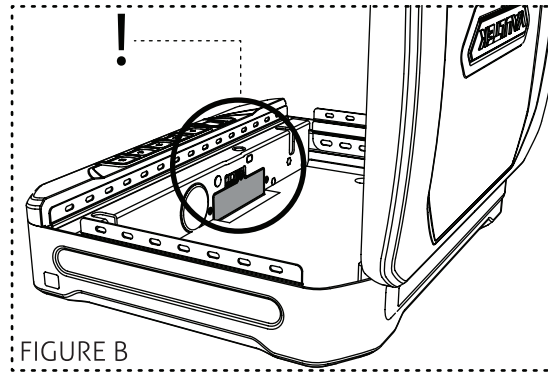

FIGURE B

Charging the Battery

Your Vaultek® safe is powered by a rechargeable lithium-ion battery and comes with a charging kit which includes an AC power adapter and a micro-USB cable. Safe and micro-USB cable can be used with all international power adapters. Under normal usage, a fully charged battery can last at up to one month.

- 1 **To recharge the safe**, plug the micro-USB cable into the micro-USB receiving jack located on the upper right side of the safe (Figure C) and connect to a standard USB port or wall outlet using the AC power adapter. Approximate recharge time is 2.5 hours.
- 2 When charging the LED light above the micro-USB jack (Figure C) will be solid RED and GREEN indicating charged.

Charging TIPS

- A After installing the battery, use the charging kit provided to charge the unit 100%.
- B The charging kit can also function as an external power supply, which means you can open your safe even when the battery is depleted.
- C Leaving your safe plugged in continually will **not** harm the safe or battery. However, to preserve battery life we suggest that you unplug occasionally to allow the battery to cycle down.
- D A specially designed Vaultek Powerpack is available as a separate accessory to extend operation time.
- E The adapter used to charge the battery should output 5V/2000mA or above when using micro-USB cable.

See the FAQ section for additional information about the battery.

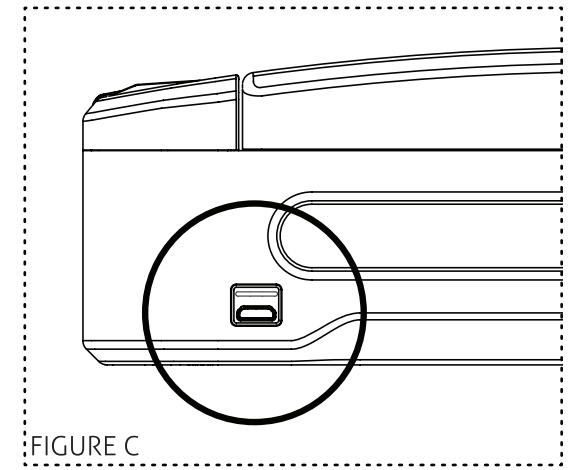

FIGURE C

Battery Maintenance

Testing the Battery Power

To check the battery level, press and hold the '5' key on the keypad for 3 seconds. The keys '1' to '4' will glow GREEN or RED to indicate the battery level:

Remaining Battery Capacity Level
If 4 keys glow green: 80%-100%
If 3 keys glow green: 60%-80%
If 2 keys glow green: 40%-60%
If 1 key glows green: 20%-40%
If 1 key glows red: 10%-20%
If 1 key blinks red: less than 10%

Low Battery

If the '1' key on the keypad blinks RED several times and you hear several rapid beeps when opening the safe, your battery level is critically low and your safe needs to be charged immediately.

Soft Reset TIP

In the event the battery dies or a soft reset is performed (battery removal and installation) the safe will restore default settings for interior light, and sound. These settings will need to be readjusted, however the master code will not be affected.

IMPORTANT

Use a 3.7V 18650 rechargeable lithium-ion battery with a flat top. A minimum 2000 mAh capacity is required, however 2200 mAh or higher can be used to increase operation time.

A high capacity battery upgrade is available as an accessory through our website.

The adapter used to charge the battery should output 5V/2000mA or above when using micro-USB cable.

TUTORIALS ONLINE AT VAULTEKSAFE.COM/20SERIES-SUPPORT

Master Code Programming

First time users should change the default code as soon as possible to prevent unauthorized access to your safe. You will also use this master code to pair the Vaultek® app on your smartphone, so it should be kept confidential.

TIP: Code Requirements

- Your code can be a minimum of 4 and a maximum of 8 digits. We recommend a code 6 to 8 digits in length using at least one of each key to make it more difficult for someone to guess your code. For your security, the safe will time out and sleep for 4 minutes if 6 incorrect entries are made.
- Two keys cannot be pressed simultaneously.
- Programming a new code will overwrite your previous code.
- **TIP!** The Vaultek® app will ask for your safe's master code during pairing and anytime you change the code the app will ask you to re-enter it.

- 1 Enter default code 1-2-3-4-5 on the keypad to open your safe.
- 2 With the safe open, press and hold the "PROGRAM" button (3 seconds) (Figure D) until all keys (1-5) light up RED and let go.
- 3 Enter your NEW master code.
- 4 Press and hold the "PROGRAM" button a second time (3 seconds) until all keys (1-5) light up RED and let go.
- 5 Enter your NEW master code a second time.
- 6 Press and hold the "PROGRAM" button a third time (3 seconds) until the safe beeps and let go. This tone confirms that the password has been reset. Now test the code.

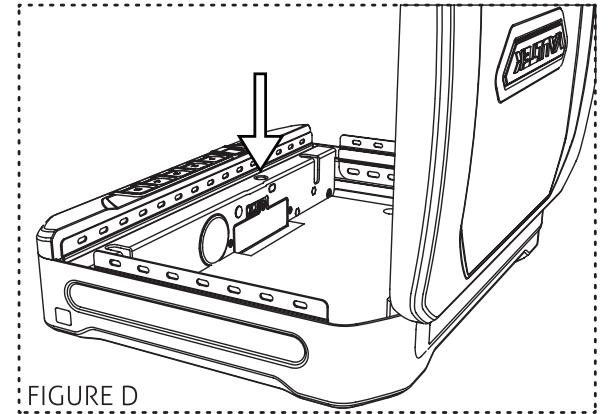

FIGURE D

If you make a mistake and the new code will not work, simply start over with step 2.

Product Registration

Vaultek® strongly encourages you to register your safe as soon as you receive it. Registration provides many benefits including technical support and ordering replacement keys should you misplace them. Your Vaultek® safe has a unique product number on the inside of the battery door and a 4-digit ID number engraved on the keys. You will need these numbers to register your safe.

- 1 Locate your product number. It is printed on the first page of this user manual and on the back of the battery door (Figure E/F).
- 2 Find your 4-digit ID number engraved on the keys (Figure G).
- 3 Please visit the Vaultek® website at vaulteksafe.com and click Support/Product Registration.
- 4 Enter the required information in the form and click submit.

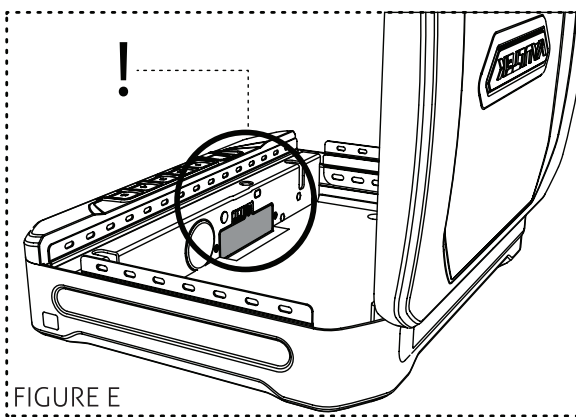

FIGURE E

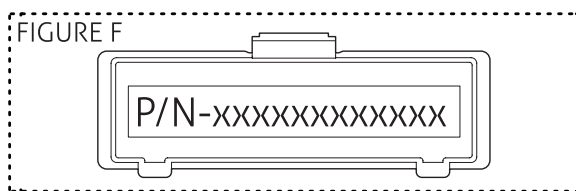

FIGURE F

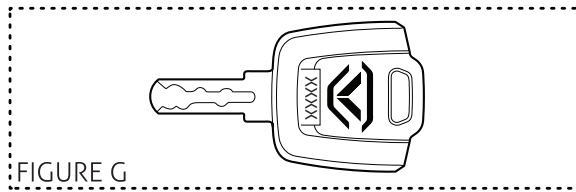

FIGURE G

TUTORIALS ONLINE AT VAULTEKSAFE.COM/20SERIES-SUPPORT

Hot Keys More Hot Keys on the next page.



Press and hold '2' and '4'

Tamper Detection

To check for tampering press and hold keys '2' and '4' together for 3 seconds. The '3' key will glow RED to indicate tampering or GREEN to indicate no tampering. You can reset the tamper detection by opening the safe through one of the authorized entry points.



Press and hold '1' and '3'

Toggle Stealth Mode

To toggle the sound ON/OFF press and hold keys '1' and '3' together for 3 seconds. If the '2' key glows GREEN, the sound is ON; if the key '2' glows RED, the sound is OFF.



Press and hold '1', '3' and '5'

Toggle Travel Mode

Save battery life by disabling the proximity sensor, keypad, and Bluetooth features. To toggle travel mode ON/OFF press and hold keys '1', '3', and '5' together until safe beeps.



Press and hold '5'

View Battery Status

To check the battery level press and hold the '5' key on the keypad (3 seconds). Keys from '1' to '4' will glow GREEN or RED to indicate the battery level. See pages 04 to 05 for more information.

If 4 keys glow green: 80%-100%

If 3 keys glow green: 60%-80%

If 2 keys glow green: 40%-60%

If 1 key glows green: 20%-40%

If 1 key glows red: 10%-20%

If 1 key blinks red: less than 10%

More Hot Keys on the next page.



Press and hold '1'

Toggle Interior Light

To toggle the interior light ON/OFF press and hold the '1' key for 3 seconds. With the light toggled to ON you can press the "LIGHT" button inside the safe to illuminate the light and can also adjust the interior light in the app. If the light is toggled OFF the light will be disabled.



Press and hold '2' and '5' then enter the master code.

Toggle Bluetooth

To toggle the Bluetooth ON/OFF press and hold keys '2' and '5' at the same time for 3 seconds. Keys '3' and '4' will glow RED indicating Bluetooth is off. To turn Bluetooth back on again, press and hold keys '2' and '5' at the same time for 3 seconds until all keys (1-5) light up RED, then input your safe's master code. Keys '3' and '4' will glow GREEN to confirm Bluetooth is enabled. With the Bluetooth toggled ON you can perform various functions on the app. If the Bluetooth is toggled OFF all app functions will be disabled and your safe is undiscoverable.

Vaultek® App Features

The Vaultek® app lets you get the most out of your safe. Using the app gives you access and control over features that are not possible using the keypad interface alone.

Helpful TIPS

History Log Timestamp Any actions recorded in the history log before your phone is paired with the safe will show a timestamp from the safe's default clock - this may not match your phone's time or date. To sync your phone's time with the safe's history log, simply remove the battery and reinstall and immediately re-sync your phone before performing any other actions.

Remote Unlock By default, the unlock feature on your app will be disabled. If you wish to enable this feature, press and hold keys '1' and '4' followed by the PROGRAM button together for 3 seconds. Repeat the sequence to disable the unlock feature.

Vaultek® App Pairing

1 Get the App Download the Vaultek® Safe app from the Google Play store or Apple store.

2 Make sure your phone's Bluetooth settings are set to ON, and **open the Vaultek® app to begin.**

IMPORTANT You must be within Bluetooth range to pair your phone with your safe. The approximate range is 25 feet.

3 Create a Pattern Lock This is an added layer of protection to safeguard your safe and prevent unauthorized access in the event your phone is misplaced. To create your pattern lock, simply drag your finger along the screen to connect at least four dots.

4 Select Your Safe After a few seconds your safe will appear in the search. You can drag the screen downwards to refresh if you are not seeing your safe listed. Select your safe, and enter your safe's master code when prompted. This is the same code used to open the safe using the numeric keypad.

IMPORTANT If you change your safe's master code after pairing, the safe will no longer connect to your app, and you will be prompted to enter the new code when needed.

IMPORTANT As a security measure, if too many incorrect master code entries are entered, your safe's Bluetooth will disable and must be toggled ON again using the hot key sequence.

5 Sync Your Phone Press and hold keys '4' and '5' on your safe followed by the PROGRAM button together for 3 seconds to start the syncing protocol. When the keypad starts blinking red you can finalize the pairing sequence from your app screen by pressing 'OK'. The safe's keypad will flash green and beep when complete, if the keypad flashes red with two beeps you will need start over with step 4.

TIP This pairing sequence offers enhanced security protection and can only be used to pair one phone to your safe. If the process is repeated with a different phone, the previous phone will be overridden and disconnected from the safe.

Remote Unlock Refer to page 09 on how to enable this feature.

Securing Your Safe

Your Vaultek® safe can be secured a few different ways. Included is a security cable to attach your safe to larger stationary objects. There are also mounting screws included to mount the safe to a flat surface using the pre-drilled holes on the bottom.

Using the Security Cable

- 1 Loop the security cable around a secured object.
- 2 Run the end of the cable through the eye of the other end and pull tight around the object.
- 3 Place the end of the security cable inside the fully enclosed quick release cable mount inside your Vaultek® safe as shown in (Figure H).
- 4 Make sure the safe closes with the cable secured inside the quick release cable mount.

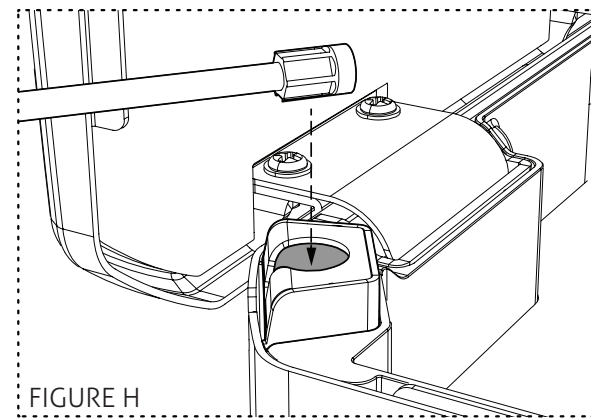

Using the Mounting Screws

TIP: Make sure you have enough clearance for the lid to open properly before mounting the safe.

- 1 Position the safe on a flat surface where you want to mount it.
- 2 Use a pencil to mark the holes for drilling.
- 3 Drill pilot holes.
- 4 Position safe in place and install screws through safe into pilot holes. Tighten screws.

IMPORTANT

Mounting the safe vertically so that the door flips upward will result in incomplete opening of the safe due to weight. The door will open if the safe is mounted vertically so that door opens down or to the side.

Customer Support / Warranty

Customer Support

If you have a problem with your Vaultek® safe that is not answered in the FAQ section of this manual, we encourage you to visit www.vaulteksafe.com/20series-support.

Limited Warranty (Terms and Conditions)

Vaultek® is committed to building high quality products and will make every effort to ensure our products are free from any defects. We guarantee your safe will be free of defects in materials or workmanship for a period of three years from the date of original purchase from an authorized dealer. This warranty does not cover abuse, misuse, use in any manner for which is not designed, neglect, modification, damage inadvertently caused by the owner, accidents, and/or tampering.

If you encounter a problem with your Vaultek® safe, contact our support team online at vaulteksafe.com/support for assistance. If your safe is determined to be defective and we are responsible for the cause we will have it repaired at our expense, or we will send a new replacement at no cost to you. You will be required to return your existing unit as well as all included accessories to Vaultek® prior to replacement of the defective unit along with your verification of purchase.

If it is determined your safe needs to be returned our customer support team will provide you with a Return Merchandise Authorization (RMA) number. Please have the following information available when contacting us:

- Purchaser's name and mailing address, email address, and phone number.
- Copy of receipt or online order number (if purchased directly from us or Amazon)
- Authorized dealer name (if applicable)
- Detailed description of problem

NEITHER SELLER NOR MANUFACTURER SHALL BE LIABLE FOR ANY INJURY, LOSS OR DAMAGE, DIRECT OR CONSEQUENTIAL, ARISING OUT OF THE USE OF, OR THE INABILITY TO USE THE VAULTEK® SAFE.

App

Q: What code is the Vaultek® app asking during pairing?

A: That is the master code used to open the safe via the numeric keypad. Refer to page 10.

Q: Why is the unlock button grayed out?

A: By default, the unlock feature on your app will be disabled. If you wish to enable this feature, press and hold keys '1' and '4' followed by the PROGRAM button together for 3 seconds. Repeat the sequence to disable the unlock feature.

Battery

Q: What happens if the battery dies?

A: The safe retains the master code in the event of battery failure. Once power is restored by inserting the charging kit, the unit will function as it did before the power loss.

Q: What type of battery does my Vaultek® safe use?

A: Use a 3.7V 18650 rechargeable lithium-ion battery with a flat top. A minimum 2000 mAh capacity is required, however 2200mAh or higher can be used to increase operation time. This type battery is commonly available and in the event you do not seek Vaultek® for a replacement we recommend a brand name like Panasonic.

Q: Can I use a battery of more than 2000mAh?

A: Yes, a minimum 2000mAh capacity is required, however 2200 mAh or higher can be used to increase operation time. An upgrade battery is available through Vaultek®.

Charging

Q: Can I keep the safe plugged in at all times?

A: Leaving your safe plugged in continually will **not** harm the safe or battery. However, to preserve the battery life span for portability we suggest that you unplug occasionally to allow the battery to cycle down.

Keys

Q: What happens if I lose the keys?

A: First, make sure you registered your safe in the event you do lose your keys. Visit Support at vaulteksafe.com for assistance in replacing a set of keys. Be prepared to provide your order details and Product Number.

Models

Q: What other models are available?

A: Refer to our website to see all the available models. Also, feel free to sign up for our newsletter to receive the latest news on all things Vaultek®.

Traveling

Q: Can I travel with my Vaultek® safe through US Customs or TSA Security at the airport?

A: Yes, there are no restrictions on carrying this type of item. Please be aware that you may be asked to open your safe. Rather than passing it through x-ray, and we recommend that an enrolled user be present during the transport of this item in case such a request is made by a government authority. If transporting a firearm, be sure the safe is checked or included with checked luggage and that you notify your airline agent at check in.

Don't see your question answered.
Send us your question to support@vaulteksafe.com.

If you experience any issues with your safe, try the following solutions.

App

The app history clock data does not match up with my phone's clock.

A: The safe's internal clock will sync with your phone automatically when paired. All previous history, before the sync, will appear from the safe's default clock and may not match your phone's clock. To sync your phone's time with the safe's history log, simply remove the battery and reinstall and immediately re-sync your phone before performing any other actions. Refer to page 09 on History Log Timestamp.

Keypad

The keypad is not responding

A: Remove the battery and reinstall. This is a soft reset for the safe. See if you are able to open the safe using the keypad or reprogram the safe's master code. If you are still experiencing issues please visit Support at vaulteksafe.com for assistance.

Keys

Q: What happens if I lose the keys?

A: First, make sure you registered your safe in the event you do lose your keys. Visit Support at vaulteksafe.com for assistance in replacing a set of keys. Be prepared to provide your order details and Product Number.

STOP! Do not return to retailer. If you have any questions about your Vaultek® safe or need help configuring the system, please contact us at support@vaulteksafe.com.

TUTORIALS ONLINE AT VAULTEKSAFE.COM/20SERIES-SUPPORT

Lid

Lid is not engaging.

A: The lid requires a firm press. You will feel the latches engage if you press slowly. Feel/listen for the click.

Lights

Lights not working.

A: To toggle the interior light ON/OFF press and hold the '1' key for 3 seconds. With the light toggled to ON you can press the "LIGHT" button inside the safe to illuminate the light and can also adjust the interior light in the app. If the light is toggled OFF the light will be disabled. If the light does not perform do a soft reset. Remove the battery and reinstall. This is a soft reset for the safe. If you are still experiencing issues please visit Support at vaulteksafe.com.

Master Code

Unable to change master code.

A: Refer to page 06 of the user manual or check our tutorials online at vaulteksafe.com under Support/Tutorials.

Sound

Sound is not working.

A: To toggle the sound ON/OFF press and hold keys '1' and '3' together for 3 seconds. If the '2' key glows GREEN, the sound is ON; if the '2' key glows RED, the sound is OFF. If the sound is toggled on and you still can't hear it, have someone else in your house listen as the sound is high pitched.

Soft Reset: Remove the battery and reinstall. The master code will not be affected. Refer to page 05 for more details.

FCC

This device has been evaluated to meet general RF exposure requirement, and this device can be used in portable exposure condition without restriction.

FCC statements:

This device complies with part 15 of the FCC rules. Operation is subject to the following two conditions: (1) this device may not cause harmful interference, and (2) this device must accept any interference received, including interference that may cause undesired operation.

NOTE: The manufacturer is not responsible for any radio or TV interference caused by unauthorized modifications or changes to this equipment. Such modifications or changes could void the user's authority to operate the equipment.

NOTE: This equipment has been tested and found to comply with the limits for a Class B digital device, pursuant to part 15 of the FCC Rules. These limits are designed to provide reasonable protection against harmful interference in a residential installation. This equipment generates uses and can radiate radio frequency energy and, if not installed and used in accordance with the instructions, may cause harmful interference to radio communications. However, there is no guarantee that interference will not occur in a particular installation. If this equipment does cause harmful interference to radio or television reception, which can be determined by turning the equipment off and on, the user is encouraged to try to correct the interference by one or more of the following measures:

- Reorient or relocate the receiving antenna.
- Increase the separation between the equipment and receiver.
- Connect the equipment into an outlet on a circuit different from that to which the receiver is connected.
- Consult the dealer or an experienced radio/TV technician for help.

CE

Due to the used enclosure material, the product shall only be connected to a USB

Do not use the product in the environment at too high or too low temperature, never expose the product under strong sunshine or too wet environment. The suitable temperature for the product and accessories is 0°C-40°C.

CAUTION RISK OF EXPLOSION IF BATTERY IS REPLACED BY AN INCORRECT TYPE. DISPOSE OF USED BATTERIES ACCORDING TO THE INSTRUCTIONS.

The adapter shall be installed near the equipment and shall be easily accessible.

EU Regulatory Conformance

Hereby, Vaultek Safe, Inc. declares that this device is in compliance with the essential requirements and other relevant provisions of Directive 1999/5/EC. For the declaration of conformity, visit the Web site <https://vaulteksafe.com>.





VAULTEK®

37 North Orange Ave. Suite 800B Orlando, FL 32801

VAULTEKSAFE.COM