



BARIKADE®

USER MANUAL

QUICK SETUP!

SCAN CODE

*USE PHONE CAMERA



or visit www.vaulteksafe.com/support/barikade/

Thank You

At Vaultek® we stand behind our product and you our customer. On behalf of the entire team thank you for your purchase. We believe personal defense should be handled seriously and we're excited for you to experience the ultimate performance in smart-security.

Quick Start Guide

- Step 1** Battery Installation (Page 03)
- Step 2** Master Code Programming (Page 04)
- Step 3** Programming the Biometric Scanner (Page 05)
- Step 4** Product Registration (Page 06)

Box Contents

- Barikade™ Safe
- High Strength Steel Security Cable
- Hardware Mounting Kit
- Owner's Manual / Quick Start Guide
- Backup Keys (2)

Table of Contents

01	Get to Know Your Barikade™ Safe	09 / 10	Programming the Biometric Scanner
02	Basic Operations	09	- Admin Prints 1 and 2
02	Secure Defense	10	- Enrolling Prints 3-20
03 / 06	Quick Start Guide	10	- Deleting Fingerprints
03	- Battery Installation	11	Hot Keys
04	- Master Code Programming	11	- Sound On/Off
05	- Programming Biometric Scanner	11	- Toggle Interior Light
06	- Product Registration	11	- Delete Fingerprints
07	Warnings	12	Securing Your Safe
08	Backup Key Access	13	FAQ
08	Using the Micro-USB Port	13	Troubleshooting
08	LED Indicators	14	Customer Support
		14	Limited Warranty

Get to Know Your Barikade™ Safe

The Vaultek® Barikade™ is a tough and rugged quick access safe. Its solid structure and penetration resistant design makes it ideal for storing valuables such as firearms, jewelry, cash and other personal items. Powered by a 9V battery, the safe combines high security with complete access control.

- 01: Anti-impact latch
- 02: Quick Release Cable Mount (Included Steel Security Cable)
- 03: Interior Mounted Hinges
- 04: Program Button (Under Battery Door)
- 05: Biometric Scanner (Only Biometric Model)
- 06: Backlit Numeric Keypad
- 07: Micro-USB Port
- 08: Manual Key Access
- 09: Status LED Light
- 10: Battery Status LED Light
- 11: Proximity Sensor

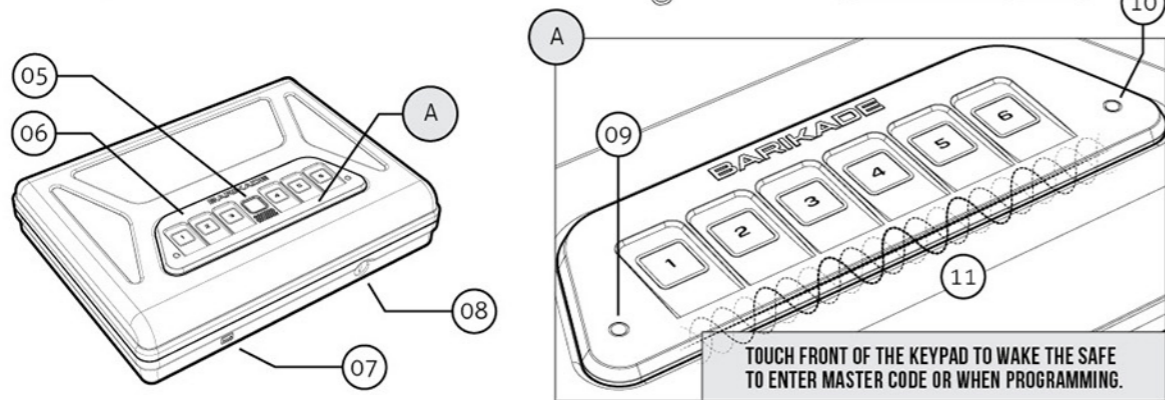
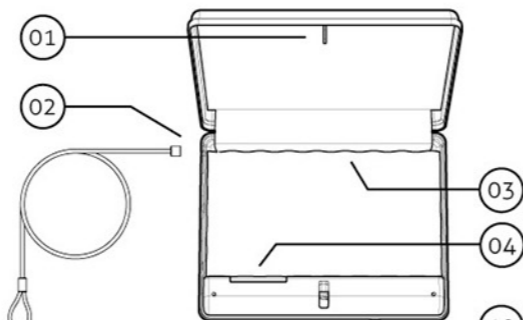

Basic Operation

With the battery installed, you can now unlock your Barikade™ safe. Unique to Barikade™ is a backlit numeric keypad with built-in proximity sensor. Touch the front of the keypad to wake the safe to enter your master code.

Keypad: The numeric keypad responds quickly for rapid access and has a built-in proximity sensor that lights up when your hand brushes against the safe. See page 04 for more information.

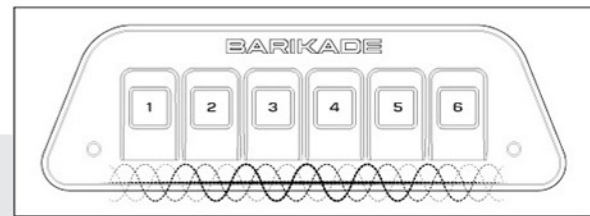

IMPORTANT! Before entering your master code you need to wake the safe by touching the front of the keypad so all the keys light up RED.

Key: Two keys are provided for manual access to the safe in the event the battery dies. See page 08.

Biometric Scanner (Biometric Model Only): Personalized access for up to 20 unique fingerprints. See pages 09 to 10 for more information. **Safe does not have to be waken to use scanner. Simply scan an enrolled print to open.**

Secure Defense: How your Vaultek® Safe keeps people out

Anti-Impact Latch: Built to withstand forceful impacts and heavy slams.

Unibody Construction: Our unibody design is extremely strong without welds or weak points.

No External Access Points: A combination of interior mounted hinges and extended anti-pry reinforcement bars help prevent unwanted tools from attempting to break the safe open.

Mounting Feature: Secure your safe to a stationary object via the included high strength steel security cable or via the two pre-drilled mounting holes using the included mounting hardware.

Security Sleep Mode: Activates when six (6 consecutive incorrect keypad entries are entered or (6) incorrect fingerprint scans are made. The safe will not accept any entries for four minutes. If any additional attempts are made the alarm will beep. The security sleep mode can be cleared upon unlock of the safe by any authorized access method including the backup keys.

Quick Start Guide

Follow the quick start guide to get your safe up and running. If you have any questions or issues please email support@vaulteksafe.com.

Quick Start Guide Battery Installation

Step 1

Barikade™ is powered by a 9v Alkaline battery (not included). Under normal use the battery can last up to one year. We recommend purchasing a name brand battery for best performance.

Step 1 To get started, insert one of your backup keys into the keyhole at the front of the safe. Push key in and rotate the key clockwise to open the safe.

Step 2 Locate the battery cover on the front wall and remove by pressing and sliding up (Figure A).

Step 3 Carefully pull out the battery snap inside the battery compartment, and connect an Alkaline 9V battery to the connector. Be sure to snap the battery in the correct orientation (Figure B).

Step 4 When the battery is snapped in you will hear a short welcome tone and the keypad will light up.

Step 5 Once you hear the tone and see the keypad light up, slide the battery into its compartment. Replace the battery cover and you are ready to program.

Troubleshooting! If you snap the battery in and the keypad is flashing then your battery is likely low. Replace the battery with a new 9v Alkaline battery. We recommend a brand name battery like Duracell or Energizer.

IMPORTANT! Your Barikade™ safe will automatically lock when you fully close the lid.

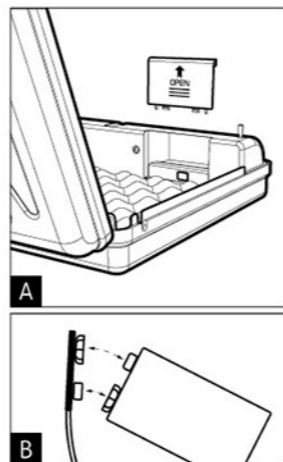

Quick Start Guide Master Code Programming

Step 2

First time users should change the default code as soon as possible to prevent unauthorized access to your safe, so it should be kept confidential.

Programming Tips!

- Program button is located underneath the battery door cover for protection.
- The default master code is 1-2-3-4.
- Your code can be as short as 4 digits, or up to 8 digits in length.
- Two keys cannot be pressed simultaneously.
- Programming a new master code will overwrite your previous code.

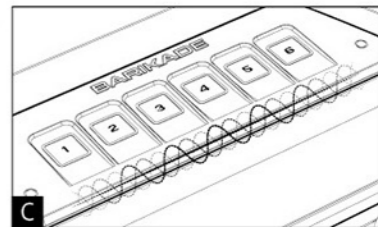

Step 1 Open the safe lid, and wake the safe by touching the front of the keypad so all the keys light up RED (Figure C).

Step 2 While safe is still awake, immediately press and hold the program button until all keys 1-6 light up and you hear the confirmation beep, then let go.

Step 3 Enter your new master code then immediately press and hold the program button a second time until all keys 1-6 light up and you hear the confirmation beep.

Step 4 Enter your new master code a second time then immediately press and hold the program button a third time until all keys 1-6 light up and you hear the confirmation beep. The status ring will light GREEN if successful.

Troubleshooting! The safe needs to be awake before programming. Be sure to place your hand near of the front of the keypad so all the keys light up RED (step 1) then proceed with steps 2-4.

Tip! Repeat this process to change the master code.

Quick Start Guide Programming the Biometric Scanner (Biometric Model) **Step 3**

Your safe can store 20 unique fingerprint IDs. The 1st and 2nd fingerprints will be recognized as administrative fingerprints and will be used to authorize additional users (3-20).

Tip! Each fingerprint requires 3 registration scans to be enrolled into the safe.

Fingerprint Tips! 1. Place the core of the fingerprint flat (Figure D) over the center of the scanner (this allows the scanner to read where most of the fingerprint detail is located). 2. Adjust your finger slightly between scans for increased accuracy. 3. Excessive moisture, lotions, or dirt will affect your fingerprint and may cause inaccurate sensor reading. 4. To use scanner the safe does not have to be awake. Simply touch the scanner to unlock.

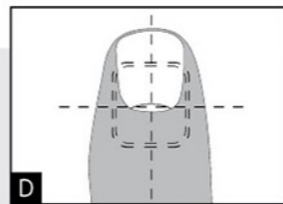

Troubleshooting! If you are having difficulty with your print, program the same fingerprint 4 or 5 times. You have 20 slots available for programming and you can also try your thumb as it has more surface area to read.

Programming Admin Prints 1 and 2: The first two enrolled fingerprints are admin prints, and are required to authorize enrolling additional users (3-20). To program additional users (3-20) refer to page 10.

Step 1 Open the safe lid, and wake the safe by touching the front of the keypad so all the keys light up RED.

Step 2 While safe is awake, quickly tap the program button to get the 1 key blinking. Place your finger on the scanner and remove it when the status LED ring turns GREEN and you hear a confirmation beep.

Step 3 With the 2 key now blinking, place your finger on the scanner at a slightly different angle and remove it when the status LED ring turns GREEN and you hear a confirmation beep.

Step 4 With the 3 key now blinking, place your finger on the scanner at a slightly different angle for the third and final registration scan and remove it when the status LED ring turns GREEN and you hear a confirmation beep. This completes enrollment for the first admin print.

Repeat steps 1-4 to enroll the second admin print. To program prints (3-20) refer to page 10.

Quick Start Guide Product Registration **Step 4**

Vaultek® strongly encourages you to register your safe as soon as you receive it. **Registration provides many benefits including three year warranty, technical support, and ordering replacement keys should you misplace them.** Your Barikade™ safe has a unique product number on the inside of the battery door and a 4-digit ID number engraved on the keys. You will need these numbers to register your safe.

Step 1 Locate your product number. It is printed on the first page of this user manual and on the back of the battery door (Figure E/F).

Step 2 Find your 4-digit ID number engraved on the keys (Figure G).

Step 3 Please visit the Vaultek® website at vaulteksafe.com and click Support/Product Registration.

Step 4 Enter the required information in the form and click submit

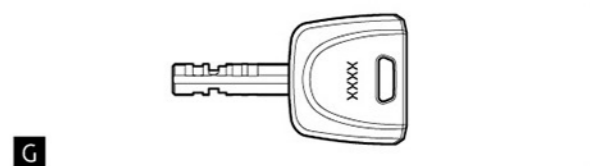
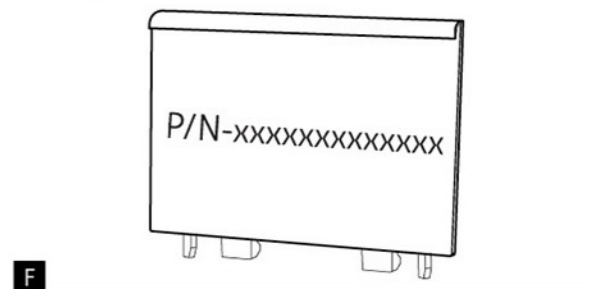
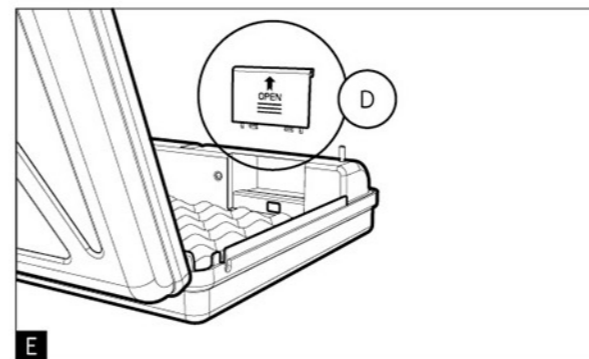

Warnings

To prevent damage to your Barikade™ unit or injury to yourself or to others, read the following safety precautions before using this unit.

DO NOT PLACE OR STORE THE BACKUP KEYS INSIDE THE SAFE AT ANY TIME. IF THE BATTERY FAILS, YOU WILL BE UNABLE TO OPEN THE SAFE.

DO NOT expose to extreme heat or cold. Battery power may be affected.

DO NOT store loaded guns in this unit. Firearms are serious in nature and must be handled with respect. Store responsibly.

DO NOT get fingerprint sensor wet.

ALWAYS check to make sure door has latched when closing; lid requires a firm press and locks automatically.

DISCLAIMERS:

NEITHER SELLER NOR MANUFACTURER SHALL BE LIABLE FOR UNAUTHORIZED ACCESS, ANY INJURY, LOSS OR DAMAGE TO PERSONAL PROPERTY DIRECT OR CONSEQUENTIAL, ARISING OUT OF THE USE OF, OR THE INABILITY TO USE THE VAULTEK® SAFE.

THE USER SHALL DETERMINE THE SUITABILITY OF THE VAULTEK® SAFE BEFORE THE INTENDED USE AND USER ASSUMES ALL RISK AND LIABILITY WHATSOEVER IN CONNECTION THEREWITH. VAULTEK® SAFES ARE NOT INTENDED TO PROTECT AGAINST ENVIRONMENTAL HAZARDS INCLUDING FIRE AND WATER.

Be sure and follow all local and state firearm laws.

DO NOT operate a firearm without proper training and experience.

Backup Key Access

The keyhole is located at the front of the safe. Two backup keys are provided. In the event these are needed to open the Barikade™, simply insert one of the backup keys, and turn the key to open the safe.

Using the Micro-USB Port

A micro-USB port is built into Barikade™ at the front of the safe. **In the event the battery dies** while traveling, and you do not have access to the backup keys, you can power on the unit using the backup micro-USB port. Simply plug in a micro-USB cable (not included) into the port. While the cable is plugged into an external power source, Barikade™ will function normally allowing you to enter the code and open the unit.

LED Indicators

Barikade's keypad has two LEDs built in to provide various feedback. The LEDs will illuminate as needed when the unit is awake. To wake the unit, touch the front of the keypad.

Status LED (Figure H) The status LED will provide feedback on various commands. It will light GREEN when correct codes are entered and RED when an incorrect code is entered.

Tamper Indication (Figure H) If the status LED is solid RED when awake, this means the unit has detected that an incorrect code or fingerprint has been entered. You can clear the tamper indicator by entering the correct master code, fingerprint, or using the backup keys.

Battery Indicator (Figure I) When the unit is awake, the battery indicator will light either GREEN or RED. GREEN indicates the battery has sufficient power, and RED indicates the battery is in need of replacement.

Low Battery Warning (Figure I) The battery indicator will flash RED and sound several rapid beeps. This continues every 5 minutes until the battery dies to indicate the battery is in need of a replacement.

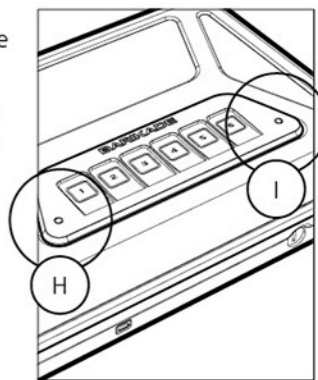

Programming the Biometric Scanner: Admin Prints 1 and 2 (Biometric Model)

The 1st and 2nd fingerprints will be recognized as administrative fingerprints and will be used to authorize additional users. To program additional users please refer to the next page.

Tip! The first two enrolled fingerprints are admin prints, and are required to authorize enrolling additional users (3-20).

Tip! Each fingerprint requires 3 registration scans to be enrolled into the safe.

Fingerprint Tips! 1. Place the core of the fingerprint flat (Figure J) over the center of the scanner (this allows the scanner to read where most of the fingerprint detail is located). 2. Adjust your finger slightly between scans for increased accuracy. 3. Excessive moisture, lotions, or dirt will affect your fingerprint and may cause inaccurate sensor reading. 4. To use scanner the safe does not have to be awake. Simply touch the scanner to unlock.

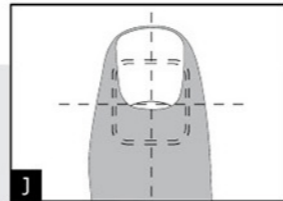

Troubleshooting! If you are having difficulty with your print, program the same fingerprint 4 or 5 times. You have 20 slots available for programming and you can also try your thumb as it has more surface area to read.

Step 1 Open the safe lid, and wake the safe by touching the front of the keypad so all the keys light up RED.

Step 2 While safe is awake, quickly tap the program button to get the 1 key blinking. Place your finger on the scanner and remove it when the status LED ring turns GREEN and you hear a confirmation beep.

Step 3 With the 2 key now blinking, place your finger on the scanner at a slightly different angle and remove it when the status LED ring turns GREEN and you hear a confirmation beep.

Step 4 With the 3 key now blinking, place your finger on the scanner at a slightly different angle for the third and final registration scan and remove it when the status LED ring turns green and you hear a confirmation beep. This completes enrollment for the first admin print.

Repeat steps 1-4 to enroll the second admin print.

Programming the Biometric Scanner: Enrolling Prints 3-20 (Biometric Model)

With both admin prints enrolled, you can enroll additional users. This safe can store up to a total of 20 different fingerprints.

Tip! When adding additional users after the admin prints the keypad will flash red and the LED around the scanner will illuminate yellow. This is prompting the scan of an admin print to authorize the request to enroll a new user.

Step 1 Open the safe lid, and wake the safe by touching the front of the keypad so all the keys light up red.

Step 2 While safe is awake, quickly tap the program button to get keypad flashing red, and the LED around the scanner to illuminate yellow. Scan one of the enrolled admin prints to authorize enrolling a new user.

Step 3 With the 1 key now blinking, place the new finger on the scanner and remove it when the status LED ring turns green and you hear a confirmation beep.

Step 4 With the 2 key now blinking, place the new finger on the scanner at a slightly different angle and remove it when the status LED ring turns green and you hear a confirmation beep.

Step 5 With the 3 key now blinking, place your new finger on the scanner at a slightly different angle for the third and final registration scan and remove it when the status LED ring turns green and you hear a confirmation beep. This completes enrollment for a new single user.

Repeat steps 1-5 to enroll additional prints.

Programming the Biometric Scanner: Deleting Fingerprints

To delete all the stored prints on the safe, first open the safe lid and wake the safe by placing your hand near the front of the keypad so all the keys light up RED. Then press and hold keys '3' and '4' at the same time until all the keys 1-6 light up and you hear the confirmation beep. Release keys '3 and 4', then enter the safe's master code.

Hot Keys

Your safe has a list of hotkeys shortcuts.



Sound On/Off: To toggle the sound ON/OFF press and hold keys '1' and '3' together for 3 seconds. If the Status LED glows GREEN, the sound is ON; if the Status LED glows RED, the sound is OFF.

Toggle Interior Light: Press and hold keys '4' and '6' together for seconds to toggle the interior light to OFF, ON for 20 seconds, or ON for 60 seconds. By default the light is toggled to ON for 20 seconds.

When the light is toggled to OFF the status LED will glow RED for 1 seconds.

When the light is toggled to ON for 20 seconds the Status LED will glow GREEN for 1 second.

When the light is toggled to ON for 60 seconds the Status LED will turn GREEN and blink 3 times.

Delete Fingerprints: To delete fingerprints press and hold keys '3' and '4' at the same time for 3 seconds until all keys (1-6) light up RED then enter your master code. This will remove all the fingerprints.

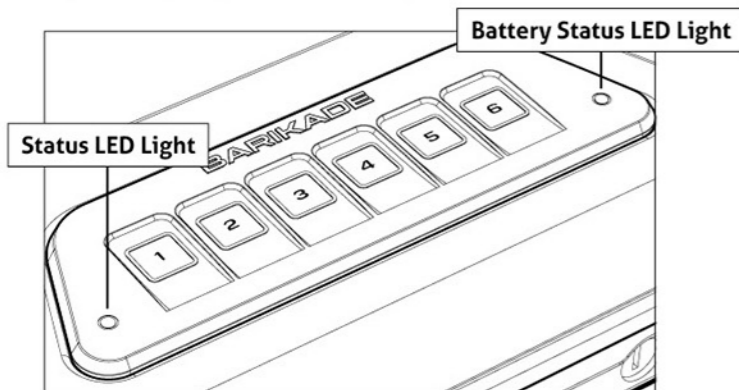

Securing Your Safe

Your Barikade™ safe can be secured a few different ways. Included is a security cable to attach your safe to larger stationary objects. There are also mounting screws included to mount the safe to a flat surface using the pre-drilled holes on the bottom.

Securing Your Safe: Using the Security Cable

Step 1 Loop the security cable around a secure object.

Step 2 Run the end of the cable through the eye of the other end and pull tight around the object.

Step 3 Place the end of the security cable inside the fully enclosed quick release cable mount inside your Barikade™ safe as shown in (Figure K).

Step 4 Make sure the safe closes with the cable secured inside the quick release cable mount.

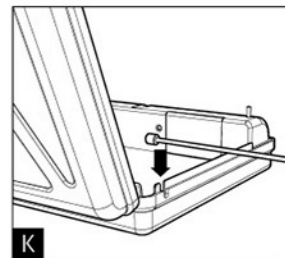

Securing Your Safe: Using the Mounting Screws

Tip! Make sure you have enough clearance for the lid to open properly before mounting the safe.

Important! Mounting the safe vertically so the door flips upward will result in incomplete opening of the safe due to the weight. The door will open if the safe is mounted vertically so that the door opens down or to the side.

Step 1 Position the safe on a flat surface where you want to mount it.

Step 2 Use a pencil to mark the holes for drilling.

Step 3 Drill pilot holes.

Step 4 Position safe in place and install screws through safe into pilot holes. Tighten screws.

FAQ More online at www.vaulteksafe.com/support/barikade

Q: What type of battery does the safe us?

A: Barikade™ is powered by a 9v Alkaline battery (not included). Under normal use the battery can last up to one year. We recommend purchasing a name brand battery for best performance.

Troubleshooting More online at www.vaulteksafe.com/support/barikade

Keypad is flashing RED after installing the battery

Your battery is likely low. Replace the battery with a new 9v Alkaline battery. We recommend a brand name battery like Duracell or Energizer.

The keypad is not responding

Remove the battery and reinstall. This is a soft reset for the safe. See if you are able to open the safe using the keypad or reprogram the safe's master code. If you are still experiencing issues please visit www.vaulteksafe.com/support/barikade for assistance.

Tip! Wake the safe before entering the master code. Touch the front of the keypad to wake the keys to turn red.

Fingerprint scanner works sometimes and not others.

If you are having difficulty with your print, program the same fingerprint 4 or 5 times. You have 20 slots available for programming and you can also try your thumb as it has more surface area to read. Also, refer to the "Fingerprint Tips" on page 09 to help improve the success rate.

Door is not engaging.

The door requires a firm press. Press the door closed all the way, allowing the door bolts to fully engage.

Sound is not working.

To toggle the sound ON/OFF press and hold keys '1' and '3' together for 3 seconds. If the Status LED glows GREEN, the sound is ON; if the Status LED glows RED, the sound is OFF. If the sound is toggled on and you still can't hear it, have someone else in your house listen as the sound is high pitched.

Customer Support

If you have a problem with your Vaultek® safe that is not answered in the Troubleshooting section of this manual, we encourage you to visit www.vaulteksafe.com/support/barikade or email support@vaulteksafe.com.

Limited Warranty

VAULTEK® IS COMMITTED TO PROVIDING PRODUCTS OF HIGH QUALITY AND VALUE AND MAKES EVERY EFFORT TO ENSURE ITS PRODUCTS ARE FREE OF DEFECTS.

Vaultek® guarantees your safe will be free of defects in materials or workmanship for a period of two years from the date of original purchase from an authorized dealer and three years with verified product registration.

The warranty is only valid for the original purchaser and not transferable. This warranty is only valid for products purchased and operated in the U.S. This warranty does not cover abuse, misuse, use in any manner for which is not designed, neglected, modification, damage inadvertently caused by the user, accidents and/or tampering.

If service is needed Vaultek will, at its option, exchange or repair without charge for parts or labor. Upon authorization of warranty service, customers are responsible for securely packaging product. Additionally, customers are responsible for costs of shipping to and from Vaultek service center.

If the claimed defect cannot be identified or reproduced, customers will be held responsible for the costs incurred. Please have the following information available before you begin a claim with Vaultek:

- Purchaser's name, mailing address, email address, and a phone number.
- Copy of receipt or online order number (if purchased directly from us or Amazon)
- Authorized Dealer Name (if applicable)
- Detailed description of the problem

NEITHER SELLER NOR MANUFACTURER SHALL BE LIABLE FOR ANY INJURY, LOSS OR DAMAGE, DIRECT OR CONSEQUENTIAL, ARISING OUT OF THE USE OF, OR THE INABILITY TO USE THE VAULTEK® SAFE.

FCC

This device complies with part 15 of the FCC rules. Operation is subject to the following two conditions: (1) this device may not cause harmful interference, and (2) this device must accept any interference received, including interference that may cause undesired operation.

NOTE: The manufacturer is not responsible for any radio or TV interference caused by unauthorized modifications or changes to this equipment. Such modifications or changes could void the user's authority to operate the equipment.

STOP! Do not return to retailer. If you have any questions about your Vaultek® safe or need help configuring the system, please visit www.vaulteksafe.com/support/barikade or email support@vaulteksafe.com.



VAULTEK®

37 North Orange Ave. Suite 770 Orlando, FL 32801

VAULTEKSAFE.COM