



SLIDER

NSL20i INSTRUCTION MANUAL

QUICK SETUP!

SCAN CODE ▶

*USE PHONE CAMERA



or visit www.vaultsafe.com/support/slider-series/

Warnings

To prevent damage to your Vaultek® unit or injury to yourself or to others, read the following safety precautions before using this unit.

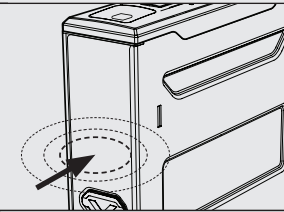

ALWAYS CHECK TO MAKE SURE THE DOOR HAS LATCHED WHEN CLOSING

This safe uses a rugged latch system. When closing, press the front door firmly closed. **Door requires a firm press and will lock automatically when closed properly.**

Change the default code as soon as possible to prevent unauthorized access to your safe.

DO NOT place or store the backup keys inside the safe at any time. If the battery fails, you will be unable to open the safe.

DO NOT expose to extreme heat or cold. Battery power may be affected.

DO NOT use a battery which has physical damage such as scratches and dents on the housing. Replace the battery every 3 years.

DO NOT store loaded guns in this unit. Firearms are serious in nature and must be handled with respect. Store responsibly.

No safe or lock is impenetrable given the right skills and tools. Vaultek® Wi-Fi® can be connected to send you live alerts of critical safe activity including tampering and when the safe is opened. See page 16 for information.

Keep this product away from small children as the package contains small items that could become a choking hazard.

Further warnings and disclaimers on next page.

DO NOT operate a firearm without proper training and experience.

Be sure and follow all local and state firearm laws.

Nano Key Warnings (Sold Separately)

Take caution when using this feature and be responsible. Security can be compromised in the event Nano Key is lost or stolen. Only pair Nano Key after thoroughly understanding the inherent risks.

To avoid unintentional safe opening, Nano Key should only be used when safe is in sight.

WARNING anyone including children can access the safe via Nano Key.

ALWAYS unpair Nano Key in the event it is lost or stolen.

Disclaimers:

NEITHER SELLER NOR MANUFACTURER SHALL BE LIABLE FOR UNAUTHORIZED ACCESS, ANY INJURY, LOSS OR DAMAGE TO PERSONAL PROPERTY DIRECT OR CONSEQUENTIAL, ARISING OUT OF THE USE OF, OR THE INABILITY TO USE THE VAULTEK® SAFE.

THE USER SHALL DETERMINE THE SUITABILITY OF THE VAULTEK® SAFE BEFORE THE INTENDED USE AND USER ASSUMES ALL RISK AND LIABILITY WHATSOEVER IN CONNECTION THEREWITH. VAULTEK® SAFES ARE NOT INTENDED TO PROTECT AGAINST ENVIRONMENTAL HAZARDS INCLUDING FIRE AND WATER.

Wi-Fi® is a registered trademark of Wi-Fi Alliance®.

Register your product online using the code on the right. Simply scan the code with your phone's camera or visit www.vaulteksafe.com, click Support, then Product Registration. Enter the required information in the form and click submit.

Registration provides many benefits including three year warranty, technical support, and ordering replacement keys should you misplace them.



Table of Contents

At Vaultek® we stand behind our product and you our customer. On behalf of the entire team thank you for your purchase. We believe personal defense should be handled seriously and we're excited for you to experience the ultimate performance in smart-security.

Quick Start Guide

- Step 1** Programming Master Code (08)
- Step 2** Programming Biometric Scanner (09 / 12)
- Step 3** Product Registration (04)

01 / 02	Get to Know Your Vaultek® Slider Series Safe	16	- Interior Light
03	Basic Operations	16	- Interior Light Time Extension
04	Product Registration	17	- Tamper Detection
05 / 07	Battery	17	- Battery Status
05	- Installation	17	- Alert of Manual Unlock
06	- Charging the Battery	17	- Nano Key Entry Modes
08	Master Code Programming	18	- Dual Entry Mode
09 / 12	Smart Align Biometric Scanner	18	- Delete Fingerprints
10	- Programming Admin Prints 1 and 2	18	- Travel Mode
11	- Programming Additional Prints 3 to 20	18	- Factory Reset
12	- Deleting Fingerprints	19 / 21	Securing Your Safe
13 / 15	Nano Key	19	- Multiple Plate Configurations
13	- Pairing	20	- Mounting Bracket Installation
14	- Entry Modes	21	- Removing Safe from Mounting Plate
14	- Unpairing	22	Troubleshooting
16	Wi-Fi Setup	23	Frequently Asked Questions
16 / 18	Hot Keys	24	Customer Support /Limited Warranty
16	- Sound		

Get to Know Your Vaultek® Slider Series Safe

The Vaultek® NSL20i part of Slider Series is a tough and rugged, quick access, Wi-Fi® enabled smart safe. Its solid structure and penetration resistant design makes it ideal for quick firearm access. Powered by a rechargeable lithium-ion battery, the safe combines high security with complete access control.

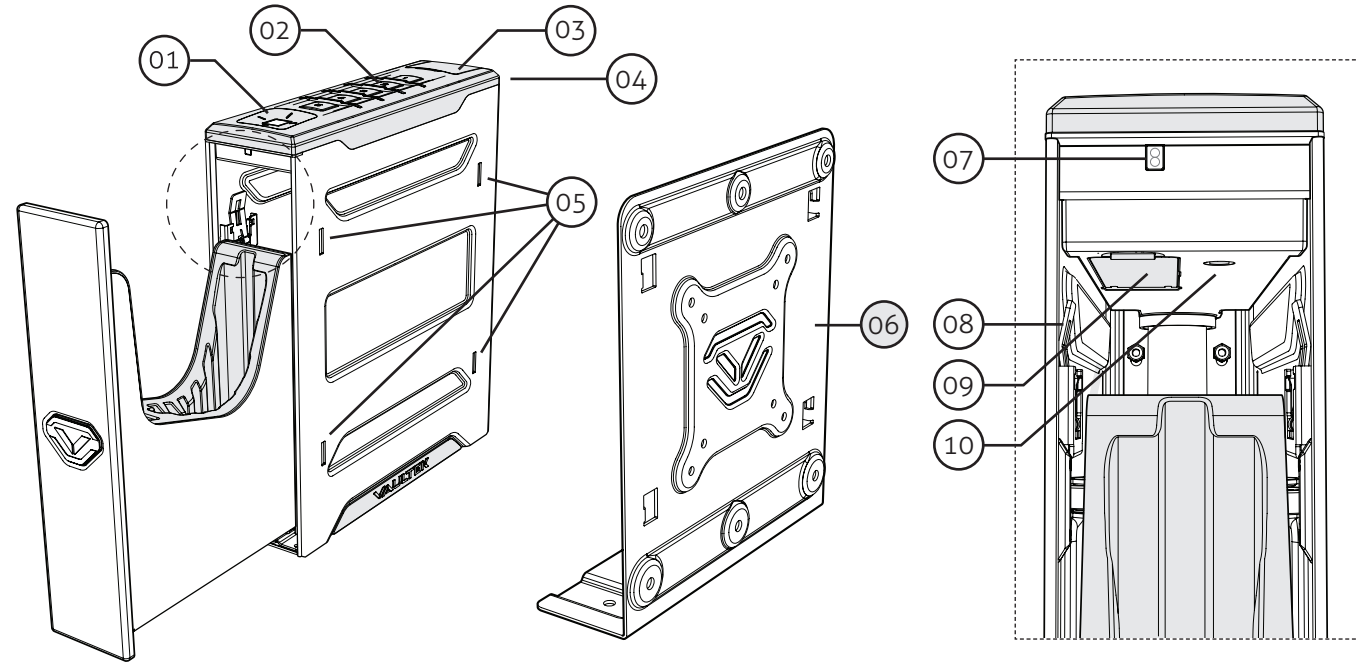

- 01. Smart Align Biometric Scanner
- 02. Backlit Keypad
- 03. Key Hole Cover

- 04. Charging Port
- 05. Mounting Slots (4x both sides)
- 06. Vaultek® Mounting Plate

- 07. LED Light
- 08. Mounting Plate Release Clip
- 09. Battery Compartment Door
- 10. PROGRAM Button

06

How to Remove Safe from the Mounting Plate

1

Open the safe. Locate the release clip on the same side as the attached mounting plate.

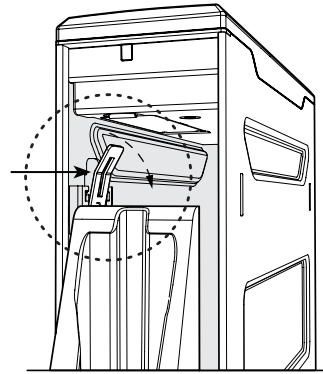

2

Use your thumb or finger to pull the release clip back, and lift the safe off the mount at the same time. The safe will not remove without pulling the release clip back.

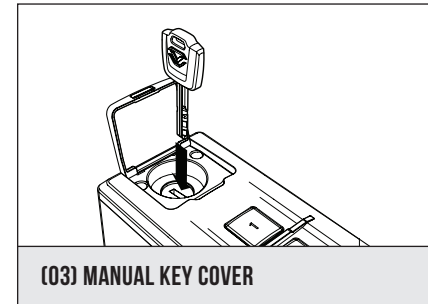
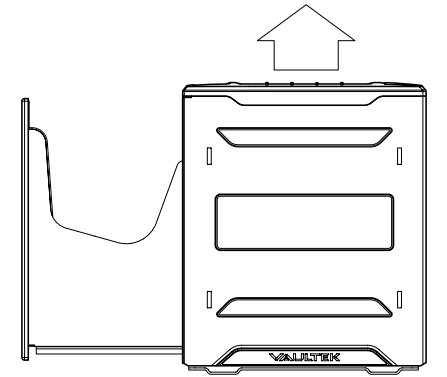

(03) MANUAL KEY COVER

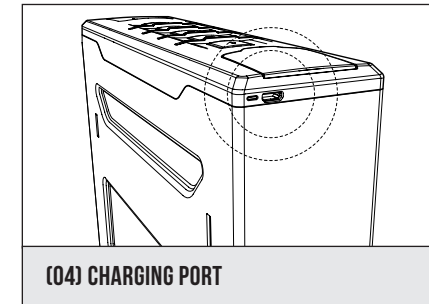

(04) CHARGING PORT

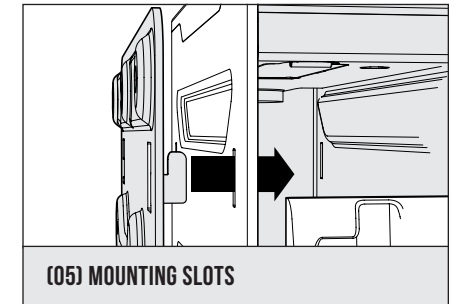

(05) MOUNTING SLOTS

For setup, tutorials, and FAQs visit www.vaulteksafe.com/support/slider-series/

Basic Operations

With the rechargeable battery installed, you can unlock your safe using any of the authorized access points.

Keypad: The numeric keypad responds quickly for rapid access and has a built-in proximity sensor that lights up when your hand brushes against the safe. See page 08 for more information.

Biometric Scanner: Personalized access for up to 20 unique fingerprints. See pages 09 to 12 for more information.

Nano Key: (Optional Accessory) Remote for on demand access. See page for 13 and 14 for more information.

Manual Key: Two keys are provided for manual access to the safe in the event the battery dies.

Before using this safe, inspect the safe to make sure the door latches properly. You can perform a quick test by using the included mechanical key. Opening and closing the safe 5 times. Do not use the product if you notice any problem or defect. Please email Vaultek customer support at support@vaulteksafe.com.

Secure Defense: How your Vaultek® safe keeps people out.

Anti-Impact Latch: Built to withstand forceful impacts and heavy slams.

Mounting Plate: Your Vaultek® safe can be secured via the included mounting plate and hardware to a vertical surface. See pages 19 and 21 for more information.

Security Sleep Mode: Activates when six (6) consecutive incorrect keypad entries are entered or (6) incorrect fingerprint scans are made. The safe will not accept any entries for four minutes. If any additional attempts are made the alarm will beep. The security sleep mode can be cleared upon unlock of the safe by any authorized access method including the backup keys.

Alert Notifications: Wi-Fi® connectivity allows you to receive live alerts during critical safe activity. This includes battery levels, tampering, and anytime the safe is opened. See page 16.

Product Registration

Vaultek® strongly encourages you to register your safe as soon as you receive it. **Registration provides many benefits including three year warranty, technical support and ordering replacement keys should you misplace them.** Your Vaultek® safe has a unique product number on the inside of the battery door and a 4-digit ID number engraved on the keys. You will need these numbers to register your safe.

- 1 Locate your product number. It is printed on the first page of this user manual and on the inside of the battery door (Figure A/B).
- 2 Find your 4-digit ID number engraved on the keys (Figure C).
- 3 Please visit the Vaultek® website at vaulteksafe.com and click Support/Product Registration.
- 4 Enter the required information in the form and click submit.

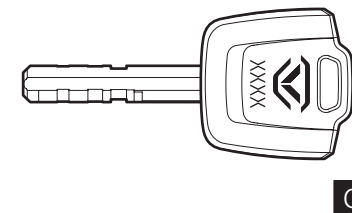
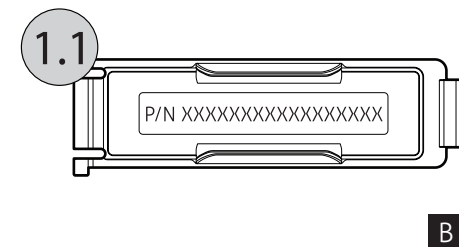
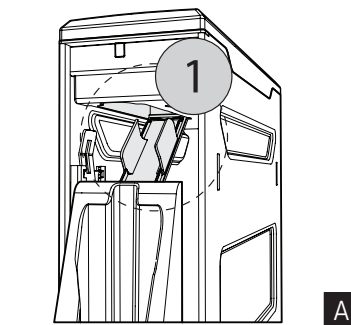

For setup, tutorials, and FAQs visit www.vaulteksafe.com/support/slider-series/

Battery: Installation

Your safe uses a 3.7V 18650 rechargeable lithium-ion battery with a flat top. A minimum 2000 mAh capacity is required, however 2200 mAh or higher can be used to increase operation time.

- 1 To get started open the safe using one of your backup keys via the keyhole at the back of the safe. Open keyhole cover, push key in and rotate key clockwise to open the safe.
- 2 Locate the battery door and open by depressing the tab near the front of the cover, allowing the door to fold down (Figure D/E).

- 3 Snap the battery (included in accessory box) into the battery door (Figure E/F). The battery door has molded snaps for the battery to clip into. Note that your Vaultek® safe automatically detects the polarity of the battery and can be snapped in either direction.

Tip! Make sure to push battery to back of the battery door allowing the door to close properly.

- 4 Close the battery door. When the battery door is closed you will hear a short welcome tone and the keypad will light up.

Important! First time users should change the default code immediately after installing the battery to prevent unauthorized access to your safe.

Important! Register your safe online. Registration provides many benefits including three year warranty, technical support and ordering replacement keys should you misplace them. Go to vaulteksafe.com/support/ then select Product Registration.

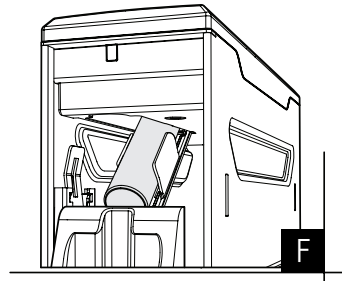
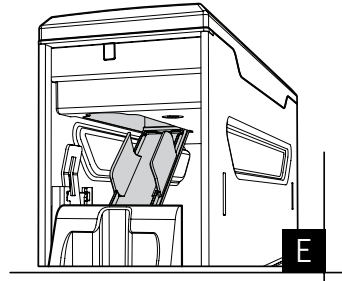
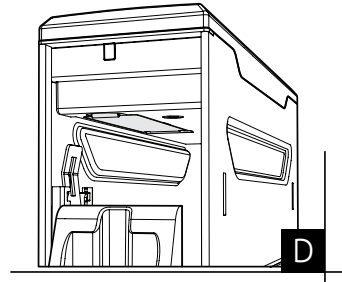

Battery: Charging

Your Vaultek® safe is powered by a rechargeable lithium-ion battery and comes with a charging kit which includes an AC power adapter and a micro-USB cable. Safe and micro-USB cable can be used with all international power adapters. Under normal usage, a fully charged battery can last at least 3 months in Low Power Mode.

Due to powerful features of this safe it is recommended to keep the safe plugged in.

- 1 **To recharge the safe**, plug the micro-USB cable into the micro-USB receiving jack located on the back side of the safe (Figure G) and connect to a standard USB port or wall outlet using the AC power adapter. Approximate recharge time is 2.5 hours.
- 2 The LED next to the receiving jack on the back of the safe (Figure G) will glow RED indicating charging and GREEN indicating charged.

Battery Maintenance: Charging Tips!

- A After installing the battery, use the charging kit provided to charge the unit 100%.
 - B The charging kit can also function as an external power supply, which means you can open your safe even when the battery is depleted.
 - C Leaving your safe plugged in continually will **not** harm the safe or battery. However, to preserve battery life we suggest that you unplug occasionally to allow the battery to cycle down.
 - D A specially designed Vaultek® powerpack is available as a separate accessory to extend operation time.
 - E The adapter used to charge the battery should output 5V/2000mA or above when using the micro-USB cable.
- See the FAQ section for additional information about the battery.

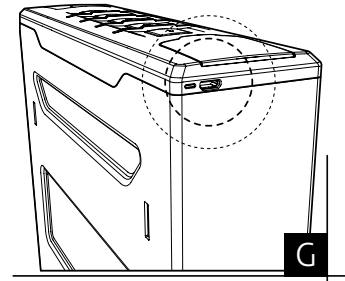

For setup, tutorials, and FAQs visit www.vaulteksafe.com/support/slider-series/

Battery: Maintenance

Battery Maintenance: Testing the Battery Power

To check the battery level, press and hold the '5' key on the keypad for 3 seconds. The keys will glow GREEN or RED to indicate the battery level:

If 4 keys glow green: 80%-100%

If 3 keys glow green: 60%-80%

If 2 keys glow green: 40%-60%

If 1 key glows green: 20%-40%

If 1 key glows red: 10%-20%

If 1 key blinks red: less than 10%

Battery Maintenance: Low Battery

If the first key blinks RED several times and you hear several rapid beeps when opening the safe, your battery level is critically low and your safe needs to be charged immediately.

Battery Maintenance: Soft Rest Tip

In the event the battery dies or a soft reset is performed (battery removal and installation) the safe will restore default settings for interior light, sound, and Alert of Manual Unlock feature. These settings will need to be readjusted, however the master code and fingerprint scanner will not be affected.

IMPORTANT! Do not use a battery which has physical damage such as scratches and dents on the housing. Replace the battery every 3 years.

IMPORTANT! Use a 3.7V 18650 rechargeable lithium-ion battery with a flat top. A minimum 2000 mAh capacity is required, however 2200 mAh or higher can be used to increase operation time.

IMPORTANT! The adapter used to charge the battery should output 5V/2000mA or above when using micro-USB cable.

Master Code Programming

WARNING! First time users should change the default code as soon as possible to prevent unauthorized access.

Code Requirements Tips!

- Your code can be a minimum of 4 and a maximum of 8 digits. We recommend a code 6 to 8 digits in length using at least one of each key to make it more difficult for someone to guess your code.
- Avoid easy-to-guess digits such as 1234, 1111, 2222, etc.
- Two keys cannot be pressed simultaneously.
- Programming a new code will overwrite your previous code.

- 1** Open the safe. Note, keys are included. With the safe open, press and hold the '1' key and "PROGRAM" button together (3 seconds) (Figure H) until all keys turn RED and let go.
- 2** Enter your NEW master code.
- 3 IMMEDIATELY** Press and hold the '1' key and "PROGRAM" button together a second time (3 seconds) until all keys turn RED and let go.
- 4** Enter your NEW master code a second time.
- 5 IMMEDIATELY** Press and hold the '1' key and "PROGRAM" button together a third time (3 seconds) until the safe beeps and all keys turn GREEN and let go. This tone confirms that the code has been reset.

Troubleshooting! If you make a mistake and the new code will not work, simply start over with step 1.

Security Sleep Mode: For your security, the safe will time out and sleep for 4 minutes if 6 incorrect entries are made.

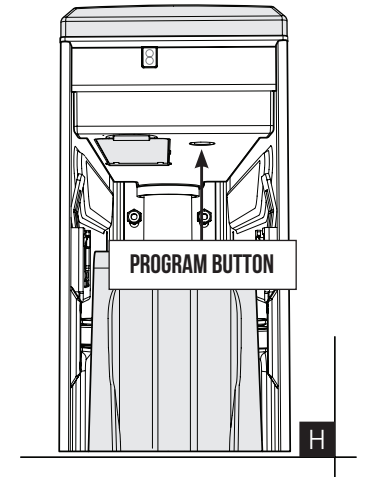

Biometric Scanner: Overview + Tips!

Biometrics are methods of authenticating the identity of a person based on physical or behavioral characteristics. Biometric fingerprint authentication refers to technology that measures and analyzes human physical characteristics for identification and authentication purposes. The smart align biometric system guides your finger placement for consistent and accurate results.

Everyone has their own unique fingerprints, and what makes them unique is the pattern of ridges, valleys, and minutiae points that comprise an individual print. Vaultek® and their leading engineering group has developed proprietary technology to read and match fingerprints with unmatched speed and accuracy. That means that only authorized users have access to your valuables. The safe is capable of storing fingerprint data for up to 20 unique authorized users. A user consists of 5 scans of the same finger during registration. Once a user's fingerprint data is stored in the safe and encrypted, it cannot be copied or stolen.

Helpful Programming Tips!

- **Place the core of the fingerprint flat** (Figure I+J+K) over the center of the scanner (this allows the scanner to read where most of the fingerprint detail is located) see (Figure I).
- Adjust your finger slightly between scans for increased accuracy (see Figure J).
- Excessive moisture, lotions, or dirt will affect your fingerprint and may cause inaccurate sensor reading.
- **Troubleshooting!** If you are having difficulty with your print, program the same fingerprint 4 or 5 times. You have 20 slots available for programming and you can also try your thumb as it has more surface area to read.

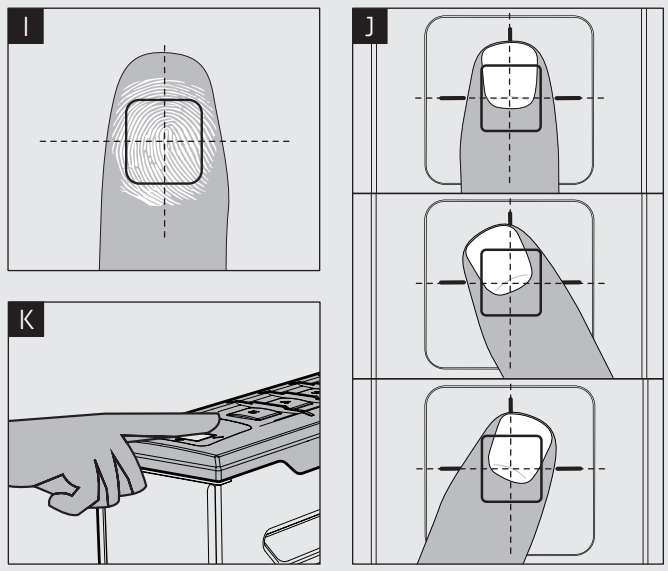

Biometric Scanner: Programming Admin Prints 1 and 2

The 1st and 2nd fingerprints will be recognized as administrative fingerprints and will be used to authorize additional users. To program additional users please refer to the next page.

Tip! The first two enrolled fingerprints are admin prints, and are required to authorize enrolling additional users (3-20).

Tip! Each fingerprint requires 5 registration scans to be enrolled into the safe.

- 1** Open the safe. Program the 1st fingerprint by pressing and holding the '2' key and "PROGRAM" button together (3 seconds) (Figure L). The fingerprint LED (Figure M) will turn solid RED and the '1' key on the keypad will start blinking RED.
- 2** Using the helpful programming tips provided on page 09 place your finger on the fingerprint scanner for the first of 5 scans. When the safe beeps and the '1' key lights up GREEN remove your finger.
- 3** Place finger again over the scanner at a slightly different angle (see Figure J on page 09) until the safe beeps and the '2' key lights up GREEN and lift.
- 4** You will repeat this process until all keys (1-5) are solid GREEN. **This completes the enrollment for the first admin.**

Tip! Repeat steps 1 through 4 to add the 2nd administrative fingerprint. To program prints (3-20) refer to page 11.

Troubleshooting! If after step 1 all the keys are blinking RED and the fingerprint LED turns solid YELLOW then refer to programming additional prints 3 to 20 on the next page.

Troubleshooting! If you are having difficulty with your print, program the same fingerprint 4 or 5 times. You have 20 slots available for programming and you can also try your thumb as it has more surface area to read.

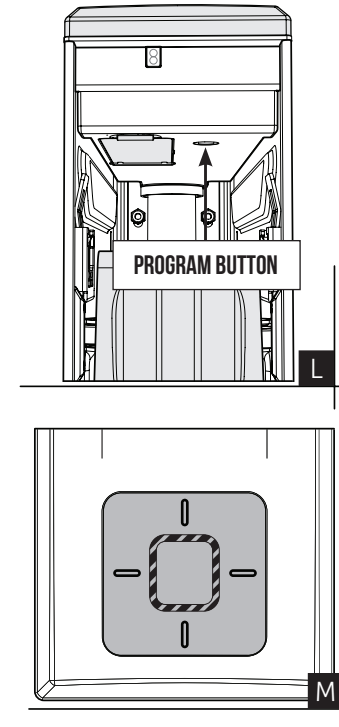

Biometric Scanner: Programming Additional Prints 3 to 20

After the first two Admin fingerprints have been locked in, you can add additional users or fingerprints, up to 20 unique users in total. This is very helpful in the event the fingerprint scanner is having a hard time reading your initial fingerprints, or if you wish to grant other users authorized access to your safe. Any additional users programmed require authorization from one of the two Admin fingerprints.

- 1 Open the safe. Program additional fingerprints by pressing and holding the '2' key and "PROGRAM" button together (3 seconds) (Figure L on page 10). When all keys (1-5) are blinking RED scan one of the administrative fingerprints.
- 2 Place one of the first two programmed administrative fingerprints on the scanner and remove when the safe beeps and the fingerprint LED blinks GREEN. When the '1' key starts blinking RED you can enroll a NEW fingerprint.
- 3 Using the helpful programming tips provided on page 09 place the NEW finger on the scanner. When the safe beeps and the '1' key lights up GREEN remove your finger.
- 4 Place finger again over the scanner at a slightly different angle until the safe beeps and the '2' key lights up GREEN and lift. You will repeat this process until all keys (1-5) are solid GREEN.

Tip! Repeat steps 1 through 4 to add additional fingerprints.

Troubleshooting! If you are having difficulty with your print, program the same fingerprint 4 or 5 times. You have 20 slots available for programming and you can also try your thumb as it has more surface area to read.

For setup, tutorials, and FAQs visit www.vaulteksafe.com/support/slider-series/

Smart Align Biometric Scanner: Deleting Fingerprints

Individual fingerprints can not be deleted from the keypad on the safe. Following this procedure will erase all of the fingerprints including both administrative fingerprints. If you wish to delete individual fingerprints, refer to the Vaultek® Wi-Fi app. This procedure will not affect the keypad master code.

- 1 Press and hold keys '3' and "PROGRAM" button together until **all** the keys light up RED and let go.
- 2 Enter your master code on the keypad. If the code is correct, all the keys will blink GREEN and safe will beep indicating deletion of **all** the fingerprints.

Smart Align Biometric Scanner: Low Success Rate

If you are having difficulty with your print, program the same fingerprint 4 or 5 times. You have 20 slots available for programming and you can also try your thumb as it has more surface area to read.

- 1 Let's delete the fingerprints and start over. Refer to the deleting fingerprints section above.
- 2 Now let's try reprogramming your fingerprint using the helpful tips on page 09.
- 3 Open the safe. Program the 1st fingerprint by pressing and holding the '2' key and "PROGRAM" button together (3 seconds) (Figure L on page 10). The fingerprint LED (Figure M on page 10) will turn solid RED and the '1' key on the keypad will start blinking RED.
- 4 Place your finger on the fingerprint scanner for the 1st of five scans until the safe beeps and the '2' key lights up GREEN and lift.
- 5 Rotate your finger position and place your finger on the scanner again. You will repeat this process until all scans (1-5) are programmed.
- 6 Close the safe and test to see if the safe will open using your fingerprint.

For setup, tutorials, and FAQs visit www.vaulteksafe.com/support/slider-series/

Nano Key

Your Vaultek® safe supports quick access with the included Nano Key. **Take caution when using this feature and be responsible. Security can be compromised in the event it is lost or stolen. Only pair Nano Key after thoroughly understanding the inherent risks.**

WARNING anyone including children can access the safe via Nano Key.

WARNING On Demand entry mode can open a safe in another room and/or out of sight. To reduce risk of an unattended open safe we recommend using Progressive entry mode.

ALWAYS unpair Nano Key in the event it is lost or stolen.

IMPORTANT! Nano Key should be mounted less than 6 feet away from the safe for proper operation. Use in long range is not recommended as it may cause accidental opens.

Nano Key: Pairing

Important! Be sure to follow **ALL** steps for proper function:

- 1 Press and hold the '5' key then "PROGRAM" button together (3 seconds) until the keypad flashes RED.
- 2 Aim Nano Key towards the safe and press the center button. If the keypad flashes GREEN then the Nano Key has paired successfully. If the keypad flashes RED then simply start over with step 1
- 3 **Set Entry Mode:** After pairing, Nano Key will be immediately active to test functionality, but then deactivate. Nano Key settings will need to be set to either On Demand or Progressive in order for Nano Key to open your safe. See next page for more information.

Troubleshooting! If Nano Key works for a moment then stops working after pairing then you need to start over with step 1. After pairing you must assign an entry mode to finalize the pairing sequence.

Nano Key: Entry Modes

After pairing you can toggle between access modes from the keypad, Wi-Fi® smartphone app, or the online Web Dashboard. To toggle modes from the safe's keypad press and hold keys '2' and '5' then "PROGRAM" button together until the keypad indicates each mode as below.

- **OFF** - Keys Turn Solid RED
- **Progressive Entry Mode** - Keys Blink GREEN: Safe goes into sleep mode and will require you to wake up the safe before using Nano Key. You can wake up the safe by pressing any key or brushing your hand across the keypad of the safe (backlit keys will turn RED).
- **On Demand Entry Mode** - Keys Solid GREEN: This mode grants immediate access to your safe without having to wake it up.

WARNING! On Demand entry mode can open a safe in another room and/or out of sight. To reduce risk of an unattended open safe we recommend using Progressive entry mode.

Important! On Demand entry mode requires significant power usage and can greatly reduce operation time. We suggest setting the Nano Key to Progressive entry mode to conserve battery, unless the safe is constantly plugged into a power outlet.

Nano Key: Unpairing

Tip! Disabling the Nano Key function from the Wi-Fi® app, Web Dashboard, or safe's keypad will NOT delete a paired key from the safe's memory. In the event a Nano Key is lost or stolen, you can delete the lost Nano Key from the safe's memory by using a couple different methods:

- A Press and hold the '5' key then "PROGRAM" button together (3 seconds) until the keypad flashes RED and times out indicating the safe deleted a paired Nano Key from memory. This is the same sequence used when initially pairing.
- B Anytime a new Nano Key is paired with the safe, the previous key will be erased from the safe's memory.

Continue on next page for more information about Nano Key.

Nano Key: Multiple Safe Management

Multiple Nano Keys can not pair with the same safe. It is recommended to pair one Nano Key per safe.

- A** Recommended setting when using the Nano Key is Progressive entry mode.
- B** You can manage multiple safes through the Vaultek® Wi-Fi® smartphone app and Web Dashboard.
- C CAUTION** when managing multiple safes in On Demand entry mode there is a chance you can open all safes within range.

Nano Key: Battery Replacement

The pre-installed battery will last approximately two years before requiring replacement. When needed follow the steps below to complete replacement.

- 1** Access the battery compartment by twisting the bottom battery cover counterclockwise, then remove the cover.
- 2** Remove the old battery by firmly lifting up on its sides to release it from its clips. A small screwdriver can help pry the battery out if used carefully.
- 3** Insert a new model CR2032 battery positive side (+) facing up. Be sure and insert the battery edge under the brass clip first (Figure N), then press firmly into place (Figure N). Replace the battery cover and twist clockwise to tighten in place.

Tip! The battery will not install correctly without first being placed under the brass clip. Damage to the remote may occur.

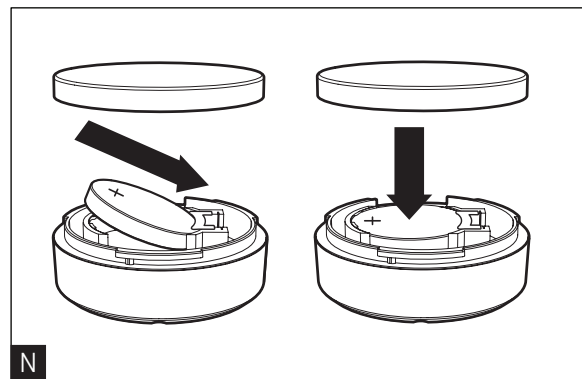

Wi-Fi Setup

Access online setup using the code on the right. Simply scan the code with your phone's camera or visit www.vaulteksafe.com/support/slider-series/ and select your model.

Tip! We suggest connecting your safe directly to the router using the Vaultek® WiFi app or with the router's WPS button. Once connected, view your safe's online dashboard at dashboard.vaulteksafe.com.

If you have any questions about your Vaultek® safe or need help configuring the system, please visit www.vaulteksafe.com/support/slider-series/ and/or email our support team at support@vaulteksafe.com.



Hot Keys

Your safe has a list of available settings that can be changed from either the safe or Vaultek® Wi-Fi app.

- | | |
|--|--|
| Sound
Press and hold '1' and '3' | To toggle the sound ON/OFF press and hold keys '1' and '3' together for 3 seconds. If all the keys glow GREEN and beeps, the sound is ON; if all the keys glow RED, the sound is OFF. |
| Interior Light
Press and hold '1' | To toggle the interior light press and hold '1' key for 3 seconds. With the light toggled ON it will illuminate when the safe opens and you can also adjust the brightness in the Vaultek® Wi-Fi® smartphone app or Web Dashboard. |
| Interior Light Time Extension
Press and hold '2' | To add additional time to the interior light press and hold the '2' key for 3 seconds. The light will turn on for an additional 10 seconds. |

More hot keys on the next page.

Hot Keys

Tamper Detection

Press and hold '2' and '4'

To check for tampering press and hold keys '2' and '4' together for 3 seconds. All the keys will glow RED to indicate tampering or GREEN to indicate no tampering. You can reset the tamper detection by opening the safe through one of the authorized entry points.

Battery Status

Press and hold '5'

To check the battery level press and hold the '5' key on the keypad (3 seconds). Keys from '1' to '4' will glow GREEN or RED to indicate the battery level. See pages 06 to 07 for more information.

If 4 keys glow green: 80%-100%

If 3 keys glow green: 60%-80%

If 2 keys glow green: 40%-60%

If 1 key glows green: 20%-40%

If 1 key glows red: 10%-20%

If 1 key blinks red: less than 10%

Alert of Manual Unlock

Press and hold '2' and '3' then "PROGRAM" button

If Alert of Manual Unlock is ON, and someone opens the safe with either the key or by picking the lock, the keypad will start flashing and beep for 10 seconds. An alert will also be sent via the Wi-Fi smartphone app or web dashboard. To toggle Alert of Manual Unlock press and hold keys '2' and '3' then "PROGRAM" button together for 3 seconds. The keypad will flash GREEN indicating enabled or RED indicating disabled. If ON and activated it can only be cleared by entering the master code or scanning an authorized fingerprint. Default is OFF.

Nano Key Entry Modes

Press and hold '2' and '5' then "PROGRAM" button

To toggle Nano Key entry modes press and hold keys '2' and '5' then "PROGRAM" button together for 3 seconds. The keypad will indicate each mode as listed on page 14. You may also alternate modes in the Vaultek® Wi-Fi smartphone app or Web Dashboard.

For setup, tutorials, and FAQs visit www.vaulteksafe.com/support/slider-series/

Dual Entry Mode

Press and hold '3' and '4' then "PROGRAM" button

To toggle Dual Entry ON/OFF press and hold keys '3' and '4' then "PROGRAM" button together for 3 seconds. The keypad will flash GREEN indicating enabled or RED indicating disabled. If Dual Entry is toggled ON, you will be required to enter your master code and fingerprint (and vice versa) to open the safe. This mode requires that at least one fingerprint be programmed into the safe.

Delete Fingerprints

Press and hold '3' and "PROGRAM" then enter master code

To delete fingerprints press and hold the '3' key and "PROGRAM" button together (3 seconds) until all keys turn RED then enter your master code. This will remove all the fingerprints. You can delete individual fingerprints in the Vaultek® Wi-Fi® smartphone app or Web Dashboard.

Travel Mode

Press and hold '1' '3' and '5'

Save battery life by disabling the proximity sensor, fingerprint sensor, keypad, Nano Key, and Wi-Fi®. To toggle travel mode ON/OFF press and hold keys '1' '3' and '5' together until the safe beeps and the keys light up. If the keys glow RED and beeps, the safe is disabled; if the keys glow GREEN and beeps, the safe is operational.

Factory Reset

Press and hold '1' and '5' then "PROGRAM" button

Press and hold keys '1' and '5' then "PROGRAM" button together for 3 seconds. **IMPORTANT** The Factory Reset erases ALL programmed information and restores the safe to its default settings. This includes any network configurations and enrolled fingerprints. The master code is reset to 1-2-3-4-5 and the safe will restart. The safe must be configured again to work with the Vaultek® Wi-Fi® smartphone app and the Web Dashboard.

For setup, tutorials, and FAQs visit www.vaulteksafe.com/support/slider-series/

Securing Your Safe

Your Vaultek® safe can be secured via the included mounting plate and hardware to a vertical surface.

Securing Your Safe: Multiple Plate Configurations

Your Vaultek® safe includes a mounting plate with multiple configurations for mounting. A four point configuration can be used for standard vertical surface mounting (1.1), two point mounting for installing in a vertical wall stud (1.2), and additional base mounts (1.3).

The mounting plate also features standard VESA 75mm and 100mm fitment for use with other adapter plates (1.4). Hardware for VESA fitment not included.

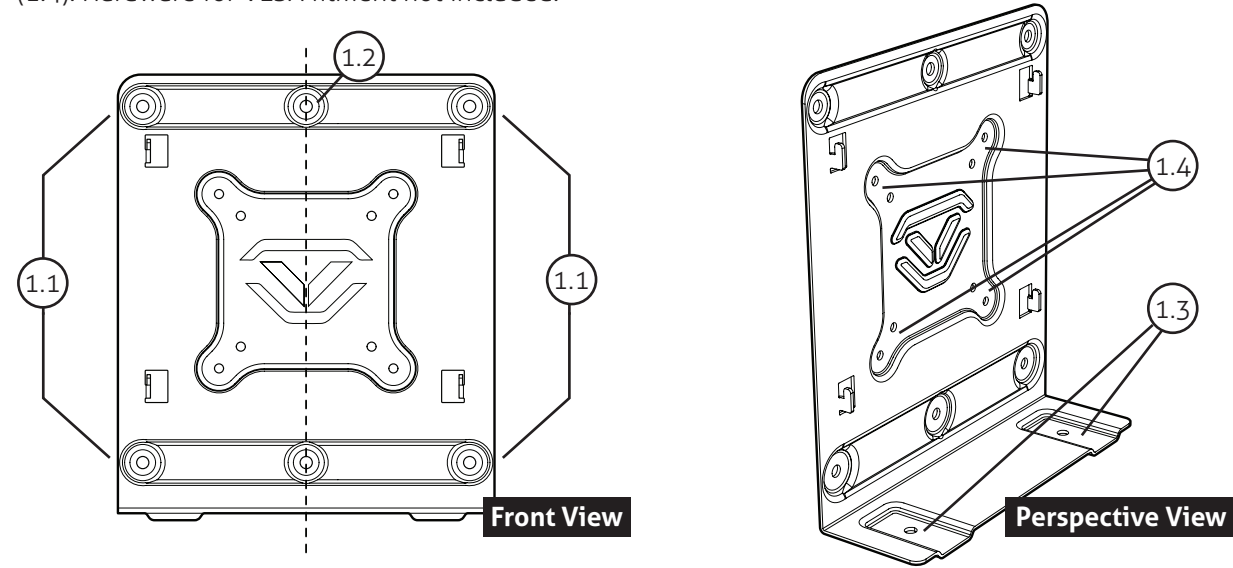

For setup, tutorials, and FAQs visit www.vaulteksafe.com/support/slider-series/

Continue on next page for more information about Securing Your Safe.

Securing Your Safe: Mounting Bracket Installation

Tip! Your safe can install on the mounting plate from the left or right side. When installing the plate, be sure the bottom is parallel to the floor (Figure Q) so the safe opens horizontally. Angling the plate or aiming the safe downwards can affect the rail mechanics and prevent safe from opening correctly.

- 1 Locate mounting surface, making sure the safe will have enough clearance to open properly prior to installing.
- 2 Hold mounting plate in place and use a pencil to mark desired hole locations. Drill 7/32" inch pilot holes.
- 3 Using hardware provided fasten mounting plate in place and tighten firmly.

Securing Your Safe: Mounting Safe

- 1 Locate the 4 receiving slots located on the safe sides, and the 4 tabs located on the mounting plate.
- 2 Fully insert the tabs on the mounting plate into the receiving slots on the safe (Figure O/P), and press the safe downwards to lock in place (Figure Q)

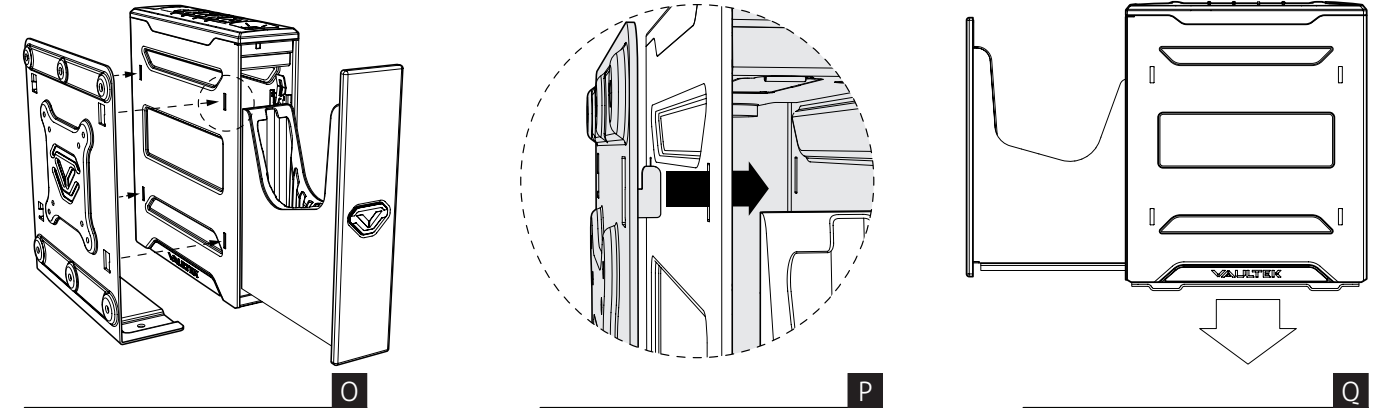

Securing Your Safe: Removing Safe from Mounting Plate

- 1 Open the safe. Locate the release clip on the same side as the attached mounting plate.
- 2 Use your thumb or finger to pull the release clip back, and lift the safe off the mount at the same time (see Figure R/S). The safe will not remove without pulling the release clip back.

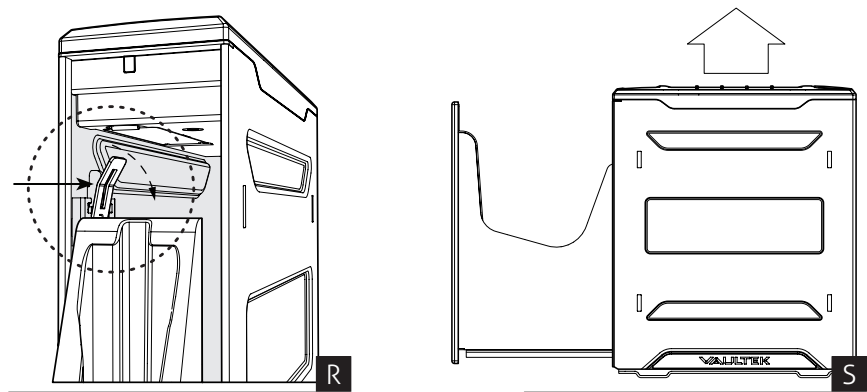

Securing Your Safe: Aftermarket Configuration

Your mounting plate features additional pre-drilled holes for the addition of aftermarket brackets or modifications (see Figure 1.4 on page 19) using VESA standard fitment. This is great if the environment requires the safe to be configured in a certain manner beyond the standard mounting options available.

For setup, tutorials, and FAQs visit www.vaulteksafe.com/support/slider-series/

Troubleshooting More online at vaulteksafe.com and select Support

If you experience any issues with your safe, try the following solutions.

Nano Key is not working. After pairing you need to assign an entry mode. Refer to pages 13 and 14. After Nano Key is paired you need to assign to either On Demand or Progressive entry mode, otherwise Nano Key will disable after pairing.

Fingerprint scanner works sometimes and not others. We have a few suggestions to help improve the success rate on page 09.

The keypad is not responding. Open and close the battery door. This is a soft reset for the safe. See if you are able to open the safe using the keypad or reprogram the safe's master code. If you are still experiencing issues please contact our support team via email at support@vaulteksafe.com or visit vaulteksafe.com and select Support for helpful tutorials.

The safe is flashing. If Alert of Manual Unlock is toggle ON, and someone opens the safe with either the key or by picking the lock, the keypad will start flashing and beep for 10 seconds. If ON and activated it can only be cleared by entering master code or scanning an authorized fingerprint. To toggle Alert of Manual Unlock press and hold keys '2' and '3' then "PROGRAM" button together for 3 seconds. The keypad will flash GREEN indicating enabled or RED indicating disabled.

Sound is not working. To toggle the sound ON/OFF press and hold keys '1' and '3' together for 3 seconds. All keys will glow GREEN, the sound is ON; if all keys glows RED, the sound is OFF. If the sound is toggled on and you still can't hear it, have someone in your house listen. The tones are high pitch.

Unable to change master code. Refer to page 08 of the user manual or check our tutorials online at vaulteksafe.com and select Support.

Additional Troubleshooting available at www.vaulteksafe.com and select Support.

STOP! Do not return to retailer. If you have any questions about your Vaultek® safe or need help configuring the system, please visit Support at vaulteksafe.com.

Frequent Asked Questions

If you have any questions about your Vaultek® safe or need help configuring the system, we encourage you to visit www.vaulteksafe.com/support. You can also email us at support@vaulteksafe.com.

Can I keep the safe plugged in at all times? Leaving your safe plugged in continually will **not** harm the safe or battery. However, to preserve the battery life we suggest that you unplug occasionally to allow the battery to cycle down.

What happens to the master code that is stored in my Vaultek® safe when the battery dies? The safe retains the master code in the event of battery failure. Once the power is restored by inserting the AC adapter cable, the unit will function as it did before the power loss.

What type of battery does my Vaultek® safe use? Use a 3.7V 18650 rechargeable lithium-ion battery with a flat top. A minimum 2000 mAh capacity is required, however 2200 mAh or higher can be used to increase operation time. This type battery is commonly available.

Can I use a battery of more than 2000 mAh? Yes, a minimum 2000 mAh capacity is required, however 2200 mAh or higher can be used to increase operation time.

What happens if I lose the keys? First, make sure you register your safe in the event you do lose your keys. Visit vaulteksafe.com and select Support for assistance. Be prepared to provide your order details and Product Number.

How do I improve fingerprint success rate?

We have a few suggestions to help improve the success rate on page 09.

Don't see your question answered.
Send us your question to support@vaulteksafe.com.

STOP! Do not return to retailer. If you have any questions about your Vaultek® safe or need help configuring the system, please visit Support at vaulteksafe.com.

Customer Support

If you have a problem with your Vaultek® safe that is not answered in the FAQ section of this manual, we encourage you to visit www.vaulteksafe.com and select Support.

Limited Warranty (Terms and Conditions)

Vaultek® IS COMMITTED TO PROVIDING PRODUCTS OF HIGH QUALITY AND VALUE AND MAKES EVERY EFFORT TO ENSURE ITS PRODUCTS ARE FREE OF DEFECTS.

Vaultek® guarantees your safe will be free of defects in materials or workmanship for a period of two years from the date of original purchase from an authorized dealer and three years with verified product registration.

The warranty is only valid for the original purchaser and not transferable. This warranty is only valid for products purchased and operated in the U.S. This warranty does not cover abuse, misuse, use in any manner for which is not designed, neglected, modification, damage inadvertently caused by the user, accidents and/or tampering.

If service is needed Vaultek will, at its option, exchange or repair without charge for parts or labor. Upon authorization of warranty service, customers are responsible for securely packaging product. Additionally, customers are responsible for costs of shipping to and from Vaultek service center.

If the claimed defect cannot be identified or reproduced, customers will be held responsible for the costs incurred. Please have the following information available before you begin a claim with Vaultek:

- Purchaser's name, mailing address, email address, and a phone number.
- Copy of receipt or online order number (if purchased directly from us or Amazon)
- Authorized Dealer Name (if applicable)
- Detailed description of the problem

NEITHER SELLER NOR MANUFACTURER SHALL BE LIABLE FOR ANY INJURY, LOSS OR DAMAGE, DIRECT OR CONSEQUENTIAL, ARISING OUT OF THE USE OF, OR THE INABILITY TO USE THE VAULTEK® SAFE.

FCC

This device has been evaluated to meet general RF exposure requirement, and this device can be used in portable exposure condition without restriction.

FCC statements:

This device complies with part 15 of the FCC rules. Operation is subject to the following two conditions: (1) this device may not cause harmful interference, and (2) this device must accept any interference received, including interference that may cause undesired operation.

NOTE: The manufacturer is not responsible for any radio or TV interference caused by unauthorized modifications or changes to this equipment. Such modifications or changes could void the user's authority to operate the equipment.

NOTE: This equipment has been tested and found to comply with the limits for a Class B digital device, pursuant to part 15 of the FCC Rules. These limits are designed to provide reasonable protection against harmful interference in a residential installation. This equipment generates uses and can radiate radio frequency energy and, if not installed and used in accordance with the instructions, may cause harmful interference to radio communications. However, there is no guarantee that interference will not occur in a particular installation. If this equipment does cause harmful interference to radio or television reception, which can be determined by turning the equipment off and on, the user is encouraged to try to correct the interference by one or more of the following measures:

- Reorient or relocate the receiving antenna.
- Increase the separation between the equipment and receiver.
- Connect the equipment into an outlet on a circuit different from that to which the receiver is connected.
- Consult the dealer or an experienced radio/TV technician for help.

For setup, tutorials, and FAQs visit www.vaulteksafe.com/support/slider-series/



VAULTEK®

37 North Orange Ave. Suite 770 Orlando, FL 32801

VAULTEKSAFE.COM